

Absolute encoders - CANopen

Shaft with clamping or synchro flange
Single turn 9...16 bit,
Multi turn 0...16 bit

FNC AC 36B & 36S Series



Features

- Encoder single - or multiturn /CANopen
- Magnetic or optical sensing
- Single turn resolution up to 21 bit
- Multi turn 0 ...32 bit
- Clamping flange or synchro flange
- Permanent check of code continuity
- Extreme resistance to shock and vibration
- Encoder with electronic reset

Technical data - electrical ratings

Voltage supply	8VDC to 30VDC
Protection:	Output short circuit protection. Reverse polarity protection (except 5V version)
Consumption w/o load	≤80 mA (24 VDC)
Interface	CANopen CiA DSP 301 V4.01, DSP 305 V1.0, DSP 406 V3.1
Resolution (steps/turn)	Magnetic: 14 bit Optic: 21 bit
Absolute accuracy	Magnetic: ±0,1° Optic: ±0,01°
Sensing method	Magnetic
Code	Binary
Code sequence	CW default, programmable
Programmable parameters	Operating modes Total resolution Scaling Rotation speed monitoring Node ID Baud Rate
Note:	All parameters change via microchip interface
Interference immunity	DIN EN 61000-6-2
Emitted interference	DIN EN 61000-6-4
Approval	CE

Technical data - mechanical design

Dimensions (flange)	ø40 mm
Shaft loading	≤40 N axial ≤80 N radial
Protection DIN EN 60529	IP54, IP65
Operating speed	≤10000 rpm
Starting torque	≤0.001Nm (IP 65)
Materials	Housing, Flange : Aluminium Shaft : Stainless steel
Shaft diameter:	6, 8, 10 mm (other diameters on request)
Bearings lifetime:	2x10 ⁹ rev. at 100% of full rated shaft load (minimum)
Operating temperature	-40...+90 °C -40 °F ...+180 °F
Weight approx.	350 g

Terminal assignment

Connector M12			
Conn.	Signals	Description	
Pin 1	n.c.	–	
Pin 2	+Vs	Supply voltage	
Pin 3	CAN_GND	CAN Ground	
Pin 4	CAN_H	Bus (dominant High)	
Pin 5	CAN_L	Bus (dominant Low)	

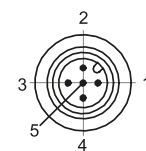

Absolute encoders - CANopen

Shaft with clamping or synchro flange
Single turn 9...16 bit,
Multi turn 0...16 bit

FNC AC 36B & 36S Series

Mechanical Dimensions

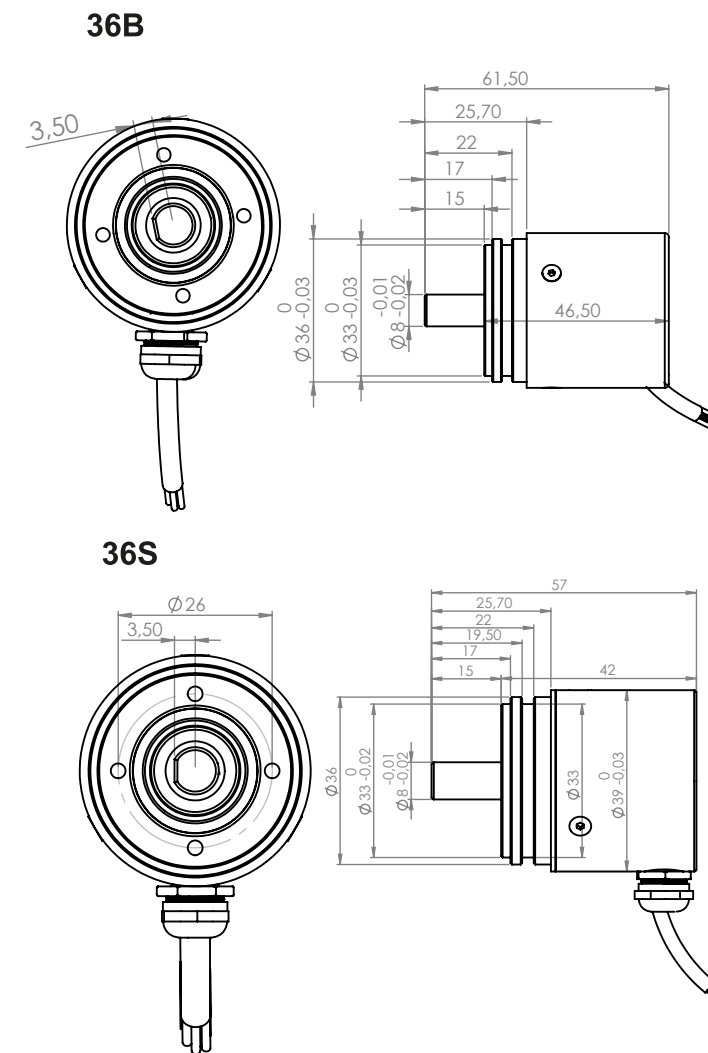

CANopen® features

Bus protocol	CANopen
Device profile	CANopen - CiA DS 406
Preset	Parameter for setting the encoder to a requested position value assigned to a defined shaft position of the system. The offset of encoder zero point and mechanical zero point is stored in the encoder.
Rotating direction	The rotating direction in which there have to be ascending or descending position values can be defined. Default setting: Ascending position values when looking at the flange and rotating the shaft clockwise.
Scaling	Parameter defining the steps per turn as well as the total resolution.
Diagnosis	The encoder supports the following error warnings: - Position error - Lithium battery voltage (multiturn)
Default	125 kbit/s, Node ID 1

Cable

Core colour	Signals	Description
white	0 V	Supply voltage
brown	+Vs	Supply voltage
green	CAN_H	Bus (dominant High)
yellow	CAN_L	Bus (dominant Low)

Encoder Part Number

