



FNC ELT 100

### Features

- Hand held manual puls encoder
- Axis select switch
- Rate override switch
- Reset switch
- 100PPR option
- Voltage output or LD output
- Operating temperature : -10...+80 °C
- Weight : 450 g
- Normal rotational speed : max 200 r / min
- Current consumption : max 60mA
- Frequency response : 5kHz

### Dimensions

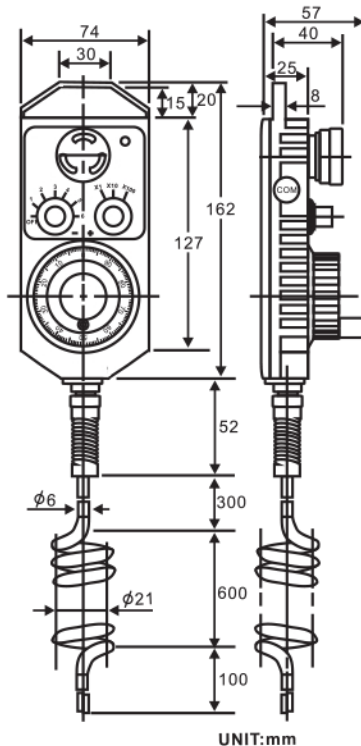

### Connection

