

Fenac Draw-Wire Sensor

Length up to 1000 mm



FNC W55 Series

172



Features

- Measurement length up to 1000 mm
- Robust aluminium housing
- Very compact design
- Protection to IP54
- Wire-actuated ancoder for all rotary encoders with 58mm servo flange and different signal outputs
- Stainless steel wire
- Drum circumference is 125 mm
- L near ty s ~ ± 0,35 %

Technical data

Measuring range	0 - 1000mm
Resolution	customer specific
Sensor element	Incremental, analog, absolute, CANopen etc.
Temperature range	20 °C +80 °C
Material:	housing: aluminium
	draw-wire: 7x7 pvc coated 304 stainless steel (Ø 0.8mm)
Wire acceleration	approx. 5g
Wire retraction	approx. 1N
Wire extension	1,5N
Protection class	IP54
Max speed	2m/s

Part number

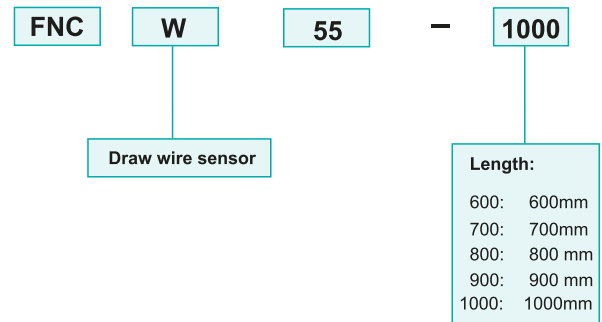

Mechanical dimensions

