



1 SAFETY PRECAUTIONS

Read the safety precautions carefully for correct usage.

※ The specifications, appearance, and measurements may change without advance notice for improvement of performance.

⚠ WARNING

1. This product has not been manufactured as a safety instrument. Thus, when using on instruments that may cause serious damage to peripherals or result in grave property loss, make sure to double equip with safety apparatus before using.
2. Do not connect to wires, inspect, or repair while power is being supplied
3. Make sure to check the terminal number before connecting to power.
4. Never disassemble, repair, reform, or upgrade this product.

- Use this product only for the purposes specified after carefully going over the safety precautions and warnings before installation and use, making sure only to use within its capacity.
- Do not wire or install on motors or solenoids with high inductive load.
- Use sealed wires when extending the sensor, and do not make the wire excessively long.
- Do not use parts that create arc upon open and close in the same power cable.
- Do not install in areas with direct sunlight, oil, water, dust, or other chemical materials.
- Do not install in areas with extreme magnetism, noise, vibration, or shock.
- Keep away from areas with strong alkali or strong acid emission and use independent piping.
- Do not spray water for cleaning if installed in kitchens.
- Do not install in areas with improper temperature or humidity.
- Do not allow the sensor wires to break or be nicked.
- Keep the sensor wire away from the signal wire, power, power supply or load wire: use independent piping.
- No customer service will be available upon arbitrary disassembly or reform of the product.
- The ⚠ mark for safety indicates warning or caution.
- Do not use near machines that create strong high frequency noise such as high frequency welding machine, high frequency sewing machine, high frequency tow-way radio, high capacity SCR controller etc.
- When improperly used not according to the producer recommendations, damage or loss in assets may occur.
- Keep away from children for this is not a toy.
- Installation must be performed only by professionals or persons with appropriate qualifications.
- We will not be responsible for any harm or losses resulting from user negligence, improper use, or not following the warning or caution provisions.

⚠ DANGER

- Danger from electrocution
 - Electric shock – Do not make contact with the AC terminal during the electric current application for this may result in electrocution.
 - When inspecting input power, make sure to cut input power.

2 Model Composition

| Model | Sensor | Temperature Range | Function | Power |
|------------------------------|--------|-------------------|------------------------|-------------------------------|
| FOX-2108 | NTC | -55.0°C ~ +99.9°C | Temperature control | AC220V |
| FOX-2208 | NTC | -55.0°C ~ +99.9°C | Temperature, alarm | AC220V |
| FOX-2208A | NTC | -55.0°C ~ +99.9°C | Temperature, two-level | AC220V |
| FOX-2108-D12 FOX-2108-D40 | NTC | -55.0°C ~ +99.9°C | Temperature control | D12:DC 12V D40:DC 24V ~40V |
| FOX-2208-D12 FOX-2208-D40 | NTC | -55.0°C ~ +99.9°C | Temperature, alarm | |
| FOX-2208-D12 FOX-2208-D40 | NTC | -55.0°C ~ +99.9°C | Temperature, two-level | |

3 Name of Parts

■ Product appearance and name of parts



- 1 Temperature output
- 2 Alarm temperature output
- 3 UP switch
- 4 Function change switch
- 5 DOWN switch

■ Changing user setting(temperature setting)

- Changing the temperature setting of the main output
 - ◀ Press this key once and the value will blink.
 - ◀ or ▶ increase or decrease by pressing these keys
- Function setting of installer mode
 - ◀ Press this key for more than 5 sec to enter the installer mode. Press ▶ ◀ to change the values.

4 Terminal connection diagram

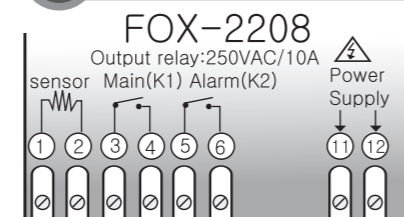

- ※ Power Supply : 230VAC 50/60Hz
- ※ Output : 250VAC 10A
Make sure of using the power relay or magnets if more than 250VAC 10A.

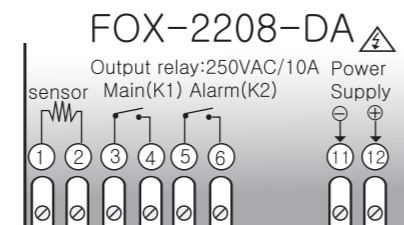

- ※ Power Supply : AC/DC 12 ~ 24V
- ※ Output : 250VAC 10A
Make sure of using the power relay or magnets if more than 250VAC 10A.

■ Example of SSR drive connection

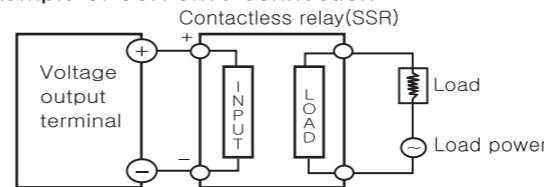

- ※ When selecting the SSR, the load capacity must be considered, and make sure of using SSR with capacity greater than that of load.

■ Example of relay connection

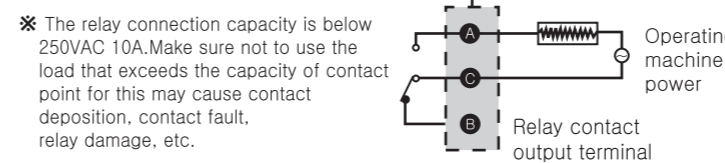

- ※ The relay connection capacity is below 250VAC 10A. Make sure not to use the load that exceeds the capacity of contact point for this may cause contact deposition, contact fault, relay damage, etc.

5 Product appearance and panel size

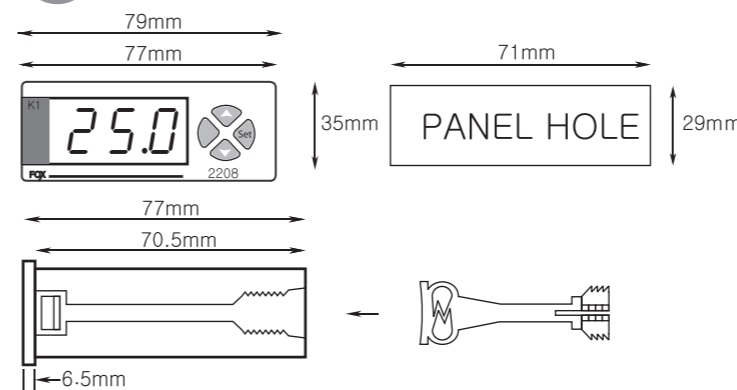

6 Setting range & set value when shipment

| | Functions | Display | Range | Set value at shipment | REMARK |
|----------------------------|---|---------|--------------|-----------------------|---|
| Setting temperature | Temp. setting | | -55.0 ~ 99.9 | 10.0 | |
| Program setting | User's setting temp. upper limit setting | HSP | LSP ~ 99.9 | 99.9 | But, irrelevant to the relay output |
| | User's setting temp. lowest limit setting | LSP | -55.0 ~ HSP | -55.0 | But, irrelevant to the relay output |
| | Function selection | LYP | CoL HEt | CoL | HEt :for heater CoL :for cooler |
| | Deviation type selection | dIF | P Pn | P | Pn Output hysteresis setting ± activation P Output hysteresis setting + activation |
| | Deviation temp. setting | dIF | 0.1 ~ 19.9 | 1.0 | |
| | Output delay time setting | dLt | 0.00 ~ 9.99 | 0.00 | min, sec |
| | Temp. correction | Cor | -5.0 ~ 5.0 | 0.0 | Difference correction between display & an actual temperature |
| | Lock function | LoC | on off | off | on : Lock function setting off : Unlock function setting except for the temp. set value. |
| | Alarm output type setting | ALS | L H | HL | L - Lock function setting H - Unlock function setting H - Upper alarm temp. |
| | Highest alarm temp. setting | HPr | | -55.0 ~ 99.9 | 99.9 |
| Lowest alarm temp. setting | LPr | | -55.0 ~ 99.9 | -55.0 | |

7 Setting value change sequence

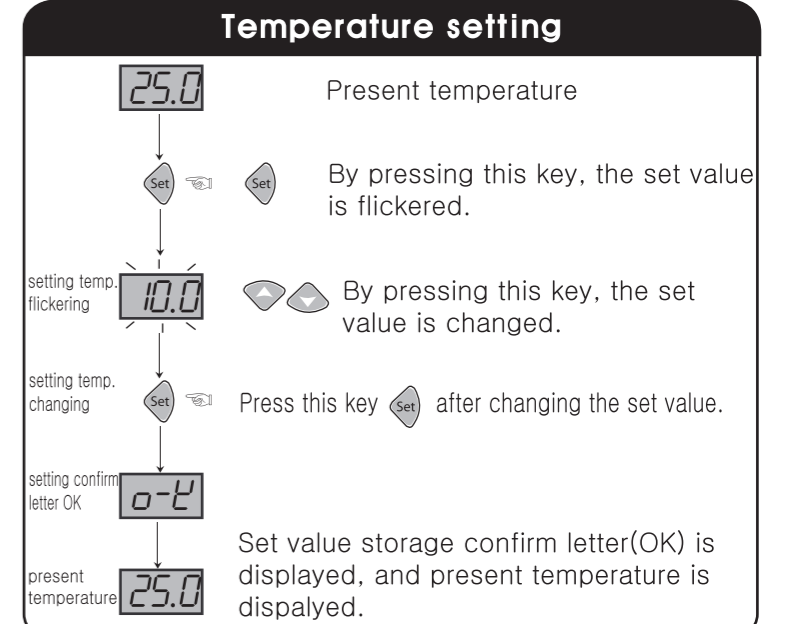

Temperature program setting

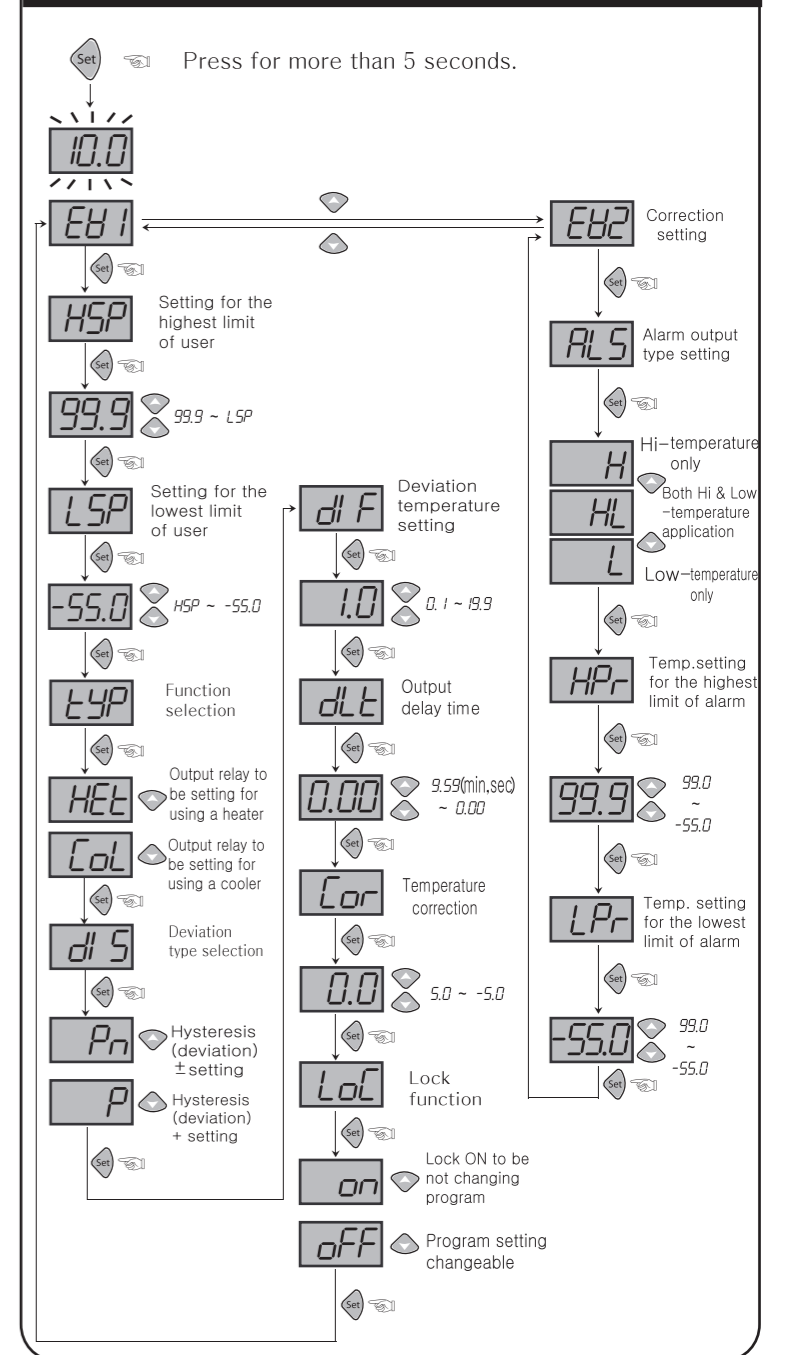

8 Detailed function description

EB1 : Changing varied setting value for a main output

EB2 : Changing varied setting value for an auxiliary output

HSP : User setting temperature upper limit point setting (maximum setting point allowed to final user). Impossible to set up the setting temperature value more than the HSP setting value.

ex) When set up the HSP = 25.0°C → Setting temp. cannot be raised over than 25.0°C

LSP : User setting temperature lower limit point setting (minimum setting point allowed to final user). It is impossible to set up the setting temperature value below than the LSP setting value.

setting point) When set up the LSP = 10.0°C → Setting temp. cannot be dropped below than 10.0°C.

LYP : Rating setting for an auxiliary output1 (Cooling & heating selection function)

When select the CoL : use as a cooler
When select the HEt : use as a heater

dI5 : Deviation type selection

P Output : Set the deviation to + activation (OFF at the setting point)

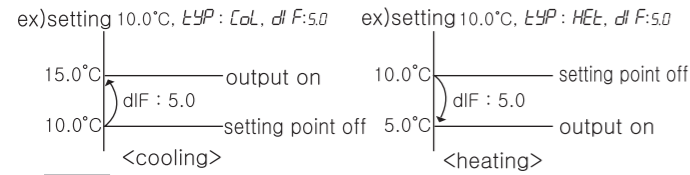

Pn Output : Set the deviation to ± activation (based on the setting point)

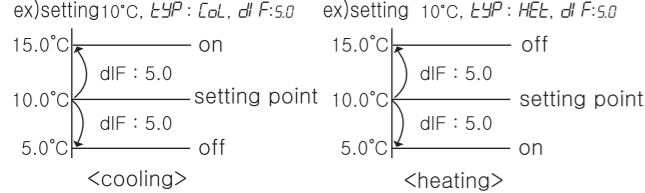

dIF : Deviation temperature setting

In the ON/OFF control, regular interval between ON and OFF is required (ON/OFF width setting)

If the ON and OFF are frequently too much activated, relay or other output contact point would be damaged quickly or hunting(power generating phenomenon, chattering) caused by exterior noise is generated.

Setting up and using the deviation temperature is the function to protect the contact point of the instrument and others etc.

for using a cooler

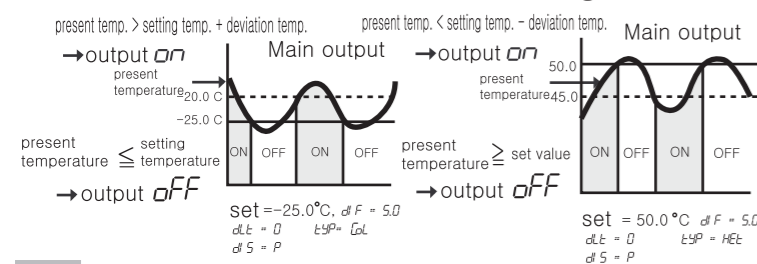

dLT Output delay time

In case of operating the ON/OFF control very often, to protect the operation machinery when re-input of the power supply or momentary stoppage of power supply.

ex) dLT set value : 1.00
The period from A point to B point is, after delay as late as dLT setting time(1min) the relay will be turned ON at B point. (OUT display is flickered for dLT time.)

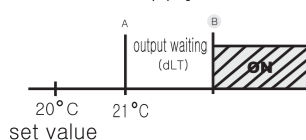

Cor : Present temperature correction function
It is a function to correct when the error occurred on the sensor input from the outside and standard temperature (ex. mercury thermometer or presently using thermometer, temperature controller) and temperature are different.

ex) Real temp. : 25.0°C
indication window : 28.0°C
* When there is 3°C difference to the real temp.
If correct the Cor from 0.0 → -3.0, 25.0°C is marked on the indication window.

LoL : Program locking function setting

LoL : Program locking

LoF : Program locking lifting

HPr : Highest limit alarm setting

Working output when temperature of the object is higher during controlling

LPPr : Lowest limit alarm setting

-Working output when temperature of the object is lower during controlling

AL5 : Alarm output type setting

H : Output ON only when the temperature is more than HPr set value.

ex) HPr : When in 50.0°C

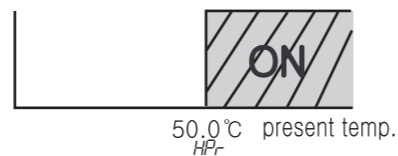

HL : All of outputs ON when the temperature is more than HPr and less than LPPr

ex) HPr : 50.0°C, LPPr : When in 10.0°C

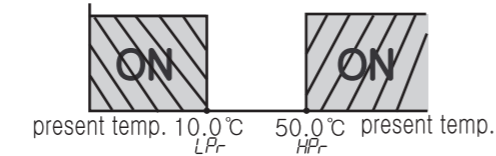

L : Present temperature is output ON when only less than LPPr

ex) LPPr : When in 10.0°C

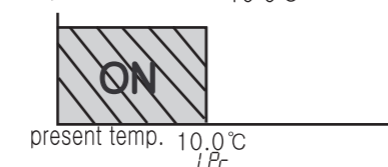

Output specification per each model

| | 2001 sensor 1EA | 2001D sensor 1EA | 2001T sensor 1EA | 2001F sensor 1EA | 2000TT sensor 1EA |
|--------|--------------------|---------------------|---------------------|---------------------|---|
| output | 1EA | 2EA | 3EA | 4EA | Controlled by temp. & time (for vinyl house using only) |

| | 2001 sensor 1EA | 2002 sensor 2EA | 2002DN general sensor | 2003 sensor 1EA | 2003S sensor 2EA | 2004 sensor 2EA | 2005 sensor 2EA | 2006 sensor 2EA |
|----------------|--------------------|--------------------|-----------------------------|--------------------|---------------------|--------------------|--------------------|----------------------|
| temp. output | ○ | ○ | ○ | ○ | ○ | ○ | ○ | temp.1 temp.2 ○ ○ |
| alarm output | - | ○ | ○ | - | - | ○ | ○ | alarm1 alarm2 ○ ○ |
| defrost output | - | - | - | ○ | ○ | ○ | ○ | - |
| FAN output | - | - | - | ○ | ○ | ○ | ○ | - |

Example of using the temperature controller

ex1)
What is the temp. and program setting value when make the heater turn off at 30.0°C and operate at 25.0°C?

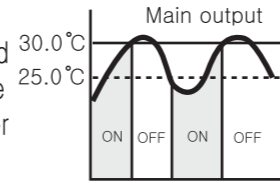

<Temp. setting >(Refer to the temp.setting mode)
setting : 30.0°C
<Program setting>(Refer to the program setting mode)
LYP : HEt
dI5 : P (one-side deviation, setting point OFF)
dIF : 5.0 (Due to on/off interval is 5.0°C)

ex2)
What is the temp. and program setting value when make the cooler turn off at 0°C and re-operate at 2.0°C?

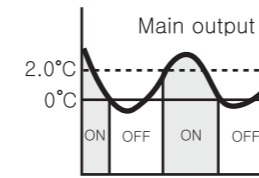

<Temp. setting >(Refer to the temp.setting mode)
setting : 0.0°C
<Program setting>(Refer to the program setting mode)
LYP : C
dI5 : P (one-side deviation, setting point OFF)
dIF : 2.0 (Due to on/off interval is 2.0°C)

9 How to diagnose a breakdown

- Indicating ERROR on using items
- This **Err** is the damage of memory data for various of inner-DATA due to be got nosied strongly from outside while using this items. Please request us A/S by return. Although our controller is designed as the complementary measures regarding these noise from outside, it is not enduring against these noise with endlessly.
- If noise(2KV) disordering become an inflow, the inner-part will be damaged.
- When shows these letter **o-E** (open error), **S-E** (short error) error in sensor. Please check sensor.

* Above product's information can be changed to improve its quality without any notification. When using this product, please observe the information of caution & warning due to give rise to disordering.

* Regarding the English-language manual, please download it at our homepage.

- H.Office : Ballyonsandan 1-ro, Jangan-eup, Gijang, Busan, Republic of Korea
- Factory : Ballyonsandan 1-ro, Jangan-eup, Gijang, Busan, Republic of Korea

- Tel : +82 (051) 819-0425~7
- FAX : 82-51-819-4562

- E-mail : conotec@conotec.co.kr
- Homepage : www.conotec.co.kr

- Main products & developments
- Digital temp./humi. controller.
- Digital timer, Current/Volt meter
- Development of other product

MEMO