

# HBS-EXP

Explosion Proof  
Single Ended Beam Load Cell



## Description

HBS-EXP is a stainless steel Single ended beam type load cell. Designed with a blast-proof structure, it is suitable for various use environments such as explosion-resistant platforms, hoppers, and tank scale.

## Specifications

Capacity(R.L.)	kgf	10, 20, 50, 100, 200, 250, 500	
Rated Output	mV / V	2.0 ± 0.005	
Zero Balance	mV / V	0.0 ± 0.02	
Accuracy Class	-	A	B
Non-Linearity	% R.O.	≤ 0.02	≤ 0.03
Hysteresis	% R.O.	≤ 0.02	≤ 0.03
Combined Error	% R.O.	≤ 0.02	≤ 0.03
Repeatability	% R.O.	≤ 0.01	≤ 0.01
Creep for 30min.	% R.O.	≤ 0.017	≤ 0.03
Return for 30min.	% R.O.	≤ 0.017	≤ 0.03
Resolution	-	≤ 1/5000	≤ 1/3000
Division	mV / V	0.0004	0.00067
Temperature Effect on	-Zero Value -Output Value	%/10°C %/10°C	≤ 0.014 ≤ 0.011
Excitation	-Recommended -Maximum	V V	10 28
Resistance	-Input -Output -Insulation	Ω Ω MΩ	400 ± 20 350 ± 3.5 > 2000
Compensated Temperature Range	°C	-10 to + 40	
Operating Temperature Range	°C	-30 to + 80	
Material & Plate	-	Stainless steel	
Cable Specification	-	Ø5 x 4P x 3m (Urethane)	
Safety Overload	% R.L.	150	

## Features

- ▶ Pressure type
- ▶ SUS type
- ▶ Hermetically sealed structure
- ▶ Essential safety explosion certificate (Ex ia IIC T4)
- ▶ Designed according to IP67

## Option

- ▶ Ball type Accessory (250kgf-2tf, 5tf, 10tf)
- ▶ HBS-EXP/Essential safety explosion certificate (Ex ia IIC T4) 10-500kgf

## Application

- ▶ Platform Scale
- ▶ Tank, Hopper Scale

## Dimensions

- ▶ Intrinsic Safety

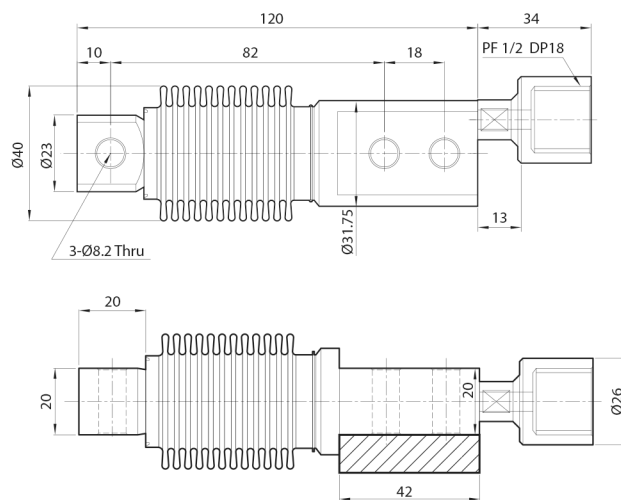

## Accessory Dimensions

► HBS

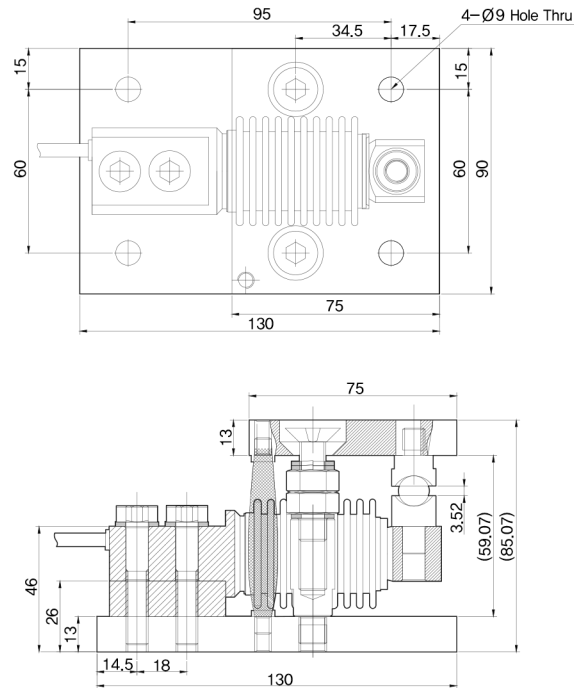

## Installation method

► HBS

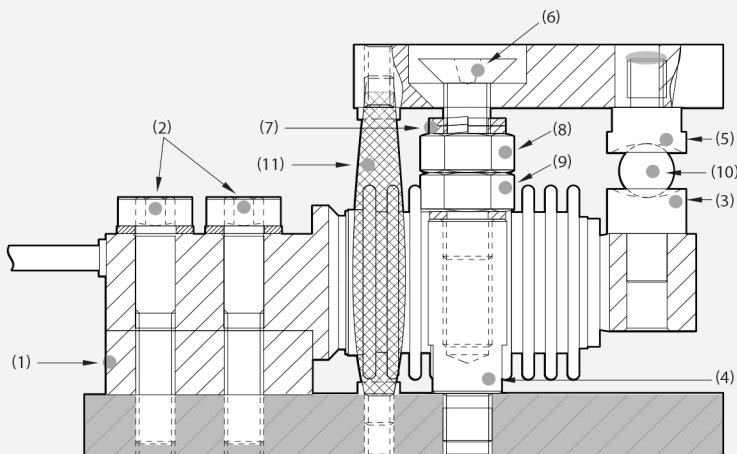

NO.	
(1)	Spacer
(2)	six-piece wrench bolt & washer
(3)	Lower ball cup
(4)	Supporter
(5)	Upper ball cup
(6)	six-piece dish head wrench bolt
(7)	Washer
(8)	Hex nut
(9)	Hex nut(Thin)
(10)	Steel ball
(11)	By-pass strap

1. Attach the spacer (1) to the base plate, and then assemble the load cell (6-angle wrench bolt and washer (2)).
2. Assemble the lower ball cup (3) on the road cell.
3. After assembling the support (4) on the base plate, apply an anti-freeze solution.
4. After assembling the upper ball cup (5) on the upper plate, apply the anti-freeze solution.
5. Tighten the six-piece dish head wrench bolt (M10) (6) on the upper plate and then the M10 Washer (7) and the M10 Nut (8) (9).
6. Combine the six - side dish head wrench bolt (M10) (6) of the upper plate with the booster (4) of the base plate (approx. 10 mm/min\_4 times).
7. Insert the ball (10) between the joined ball cup (3) (5).
8. Tighten the nut (9) so that it is fully secured to the support (4) and apply an anti-freeze solution.
9. Connect By-pass strap (11) to the upper plate and the base plate.
10. Lower the nut (8) and adjust it appropriately to obtain approval for the load.