

Limit Switch

KL Series



Part Number Description

KL 1

1 Head Type	S-A-P1 : Push Plunger	S-A-P2 : Roller Plunger	S-A-L1 : Roller Lever Plunger	S-A-L2 : Roller Lever
	S-A-L4 : Adjustable Roller Lever	S-A-L3 : Adjustable Rod Lever		
	L-A-P1 : Push Plunger	L-A-P2 : Roller Plunger	L-A-L1 : Roller Lever Plunger	L-A-L2 : Roller Lever
	L-A-L4 : Adjustable Roller Lever	L-A-L3 : Adjustable Rod Lever		
	M-A-P1 : Push Plunger	M-A-P2 : Roller Plunger	M-A-L1 : Roller Lever Plunger	M-A-L2 : Roller Lever
	M-A-L4 : Adjustable Roller Lever	M-A-L3 : Adjustable Rod Lever		

General Specification

Contact Form	1N/O + 1N/C
Contact Material	Ag alloy
Insulation Resistance	100MΩ 500VDC
Contact Resistance	Max. 50mΩ
Max. Allowable Inrush current	0.2A 125VDC

	Voltage	Non-Inductive				Inductive			
		Resistance Load		Lamp Load		Inductive Load		Motor Load	
		Normal Open (N/O)	Normal Close (N/C)	Normal Open (N/O)	Normal Close (N/C)	Normal Open (N/O)	Normal Close (N/C)	Normal Open (N/O)	Normal Close (N/C)
Contact Ratings	125VAC	10A	10A	1.5A	3A	2.5A	5A	6A	6A
	250VAC	10A	10A	1A	2A	1.5A	3A	4A	4A
	600VAC	1A	3A	0.5A	1A	0.5A	1A	1.5A	1.5A
	8VDC	10A	10A	3A	6A	6A	6A	10A	10A
	30VDC	6A	6A	3A	4A	4A	4A	6A	6A
	125VDC	0.8A	0.8A	0.2A	0.2A	0.2A	0.2A	0.8A	0.8A

·The above figure means the normal current.
 ·The Inductive load has the power factor of 0.4 or above (AC) and a correction factor of 7m/s or lower (DC).
 ·The lamp load generates approx. 10 times more inrush current, while the motor load generates 6 times more.

Operation Speed	0.01mm/sec ~ 0.5m/sec	Shock Resistance	Destruction	Plunger Max. 30G	
On/Off Frequency	Electrical	Max. 30 Min.		Lever Max. 20G	
	Mechanical	Max. 120 Min.	Malfunction	Max. 100G	
Dielectric Strength	Between the terminals of the same polarity	1,000VAC 1Min.	Life Cycle	Mechanical	Min 500,000
	Between the charging metal pieces and the earth	2,000VAC 1Min.		Electrical	Min 1,000,000
Dielectric Strength	Between each terminal and non-charging metal parts	2,000VAC 1Min.	Ambient Temperature	-25°C ~ +80°C (with no icing)	
	Vibration Resistance	10Hz ~ 55Hz Dual wave length 1.5mm	Ambient Humidity	35% ~ 85% RH	
Tightening Torque	0.8N·m (8.16kgf·cm)				

☞ The above specification and the material can be changed without notice for the improvement of the quality.

Rev. 2/14

Data subject may change without notice.





www.kacon.co.kr

Industrial Controls Catalog

III - 45

KACOM



Product Selection

	Part Number	Contact	Head Type	OF	RF	PT	MD	OT	TF
	K-L-SAP1	1N/O+1N/C	Push Plunger	2,720g	910g	1.7mm	1.0mm	6.4mm	-
	K-L-SAP2	1N/O+1N/C	Roller Plunger	2,720g	910g	1.7mm	1.0mm	5.6mm	-
	K-L-SAL1	1N/O+1N/C	Roller Lever Plunger	700g	170g	4.5mm	1.0mm	6.4mm	-
	K-L-SAL2	1N/O+1N/C	Roller Lever	1,360g	227g	20° ±5	12°	40°	200g
	K-L-SAL4	1N/O+1N/C	Adjustable Rod Lever	142g	28g	20° ±5	12°	40°	200g
	K-L-SAL3	1N/O+1N/C	Adjustable Roller Lever	1,360g	227g	20° ±5	12°	40°	200g





Limit Switch

KL Series

Product Selection

	Part Number	Contact	Head Type	OF	RF	PT	MD	OT	TF
	K-L-LAP1	1N/O+1N/C	Push Plunger	2,720g	910g	1.7mm	1.0mm	6.4mm	-
	K-L-LAP2	1N/O+1N/C	Roller Plunger	2,720g	910g	1.7mm	1.0mm	5.6mm	-
	K-L-LAL1	1N/O+1N/C	Roller Lever Plunger	700g	170g	4.5mm	1.0mm	6.4mm	-
	K-L-LAL2	1N/O+1N/C	Roller Lever	1,360g	227g	20° ±5	12°	40°	200g
	K-L-LAL4	1N/O+1N/C	Adjustable Rod Lever	142g	28g	20° ±5	12°	40°	200g
	K-L-LAL3	1N/O+1N/C	Adjustable Roller Lever	1,360g	227g	20° ±5	12°	40°	200g

Product Selection

	Part Number	Contact	Head Type	OF	RF	PT	MD	OT	TF
	K-L-MAP1	1N/O+1N/C	Push Plunger	2,720g	910g	1.7mm	1.0mm	6.4mm	-
	K-L-MAP2	1N/O+1N/C	Roller Plunger	2,720g	910g	1.7mm	1.0mm	5.6mm	-
	K-L-MAL1	1N/O+1N/C	Roller Lever Plunger	700g	170g	4.5mm	1.0mm	6.4mm	-
	K-L-MAL2	1N/O+1N/C	Roller Lever	1,360g	227g	20° ±5	12°	40°	200g
	K-L-MAL4	1N/O+1N/C	Adjustable Rod Lever	142g	28g	20° ±5	12°	40°	200g
	K-L-MAL3	1N/O+1N/C	Adjustable Roller Lever	700g	170g	4.5mm	1.0mm	6.4mm	200g

Limit Switch

KL Series

Dimension

unit : mm

KLS-A-P1

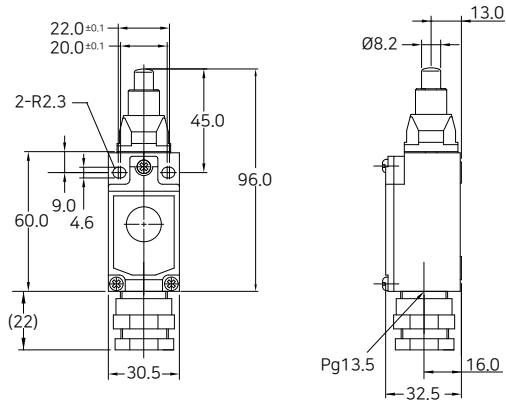

KLS-A-P2

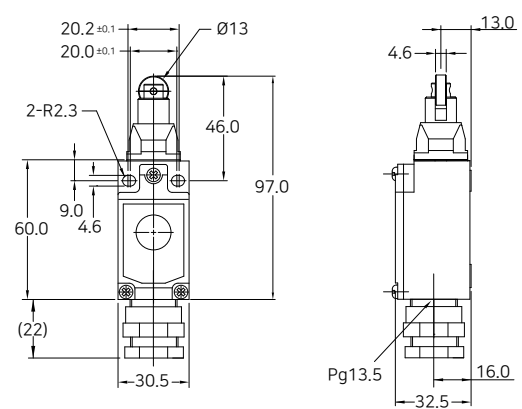

KLS-A-L1

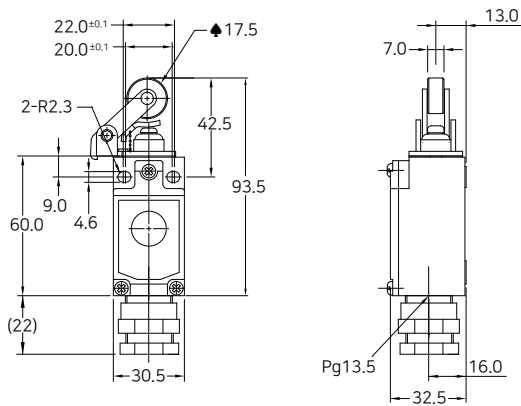

KLS-A-L2

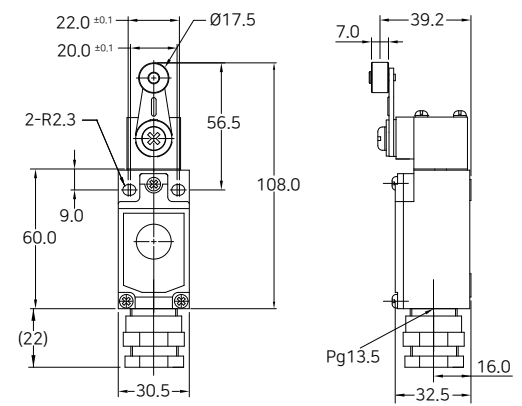

KLS-A-L3

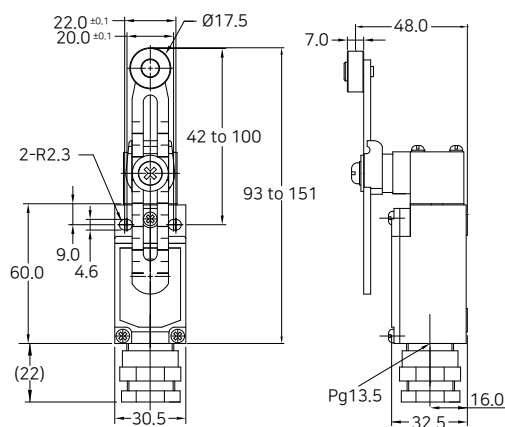

KLS-A-L4

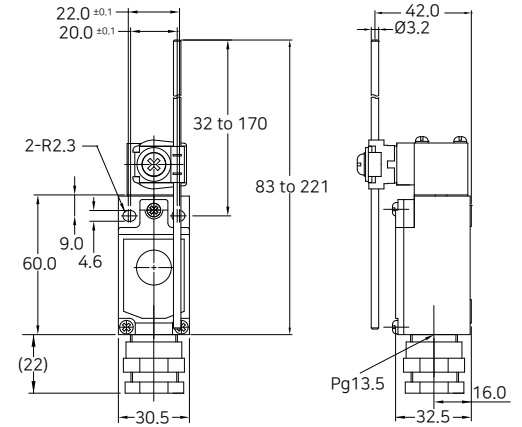

Dimension

unit : mm

KLL-A-P1

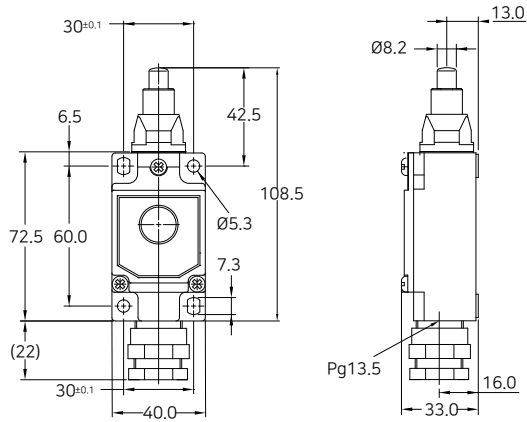

KLL-A-P2

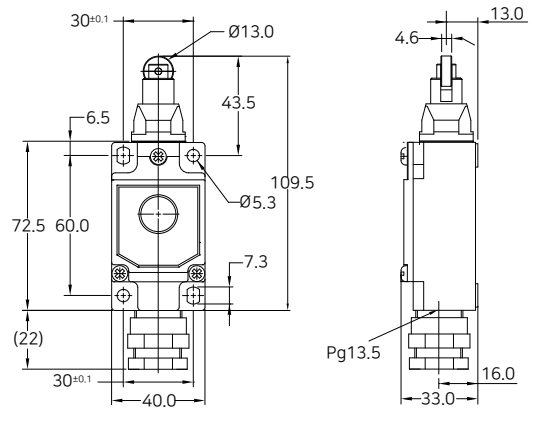

KLL-A-L1

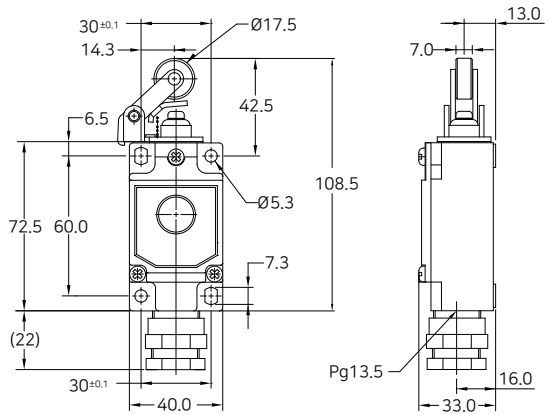

KLL-A-L2

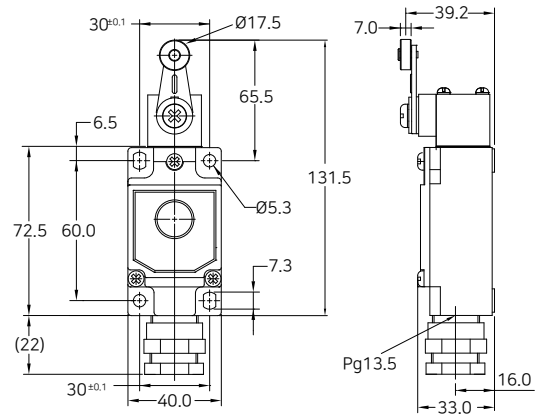

KLL-A-L3

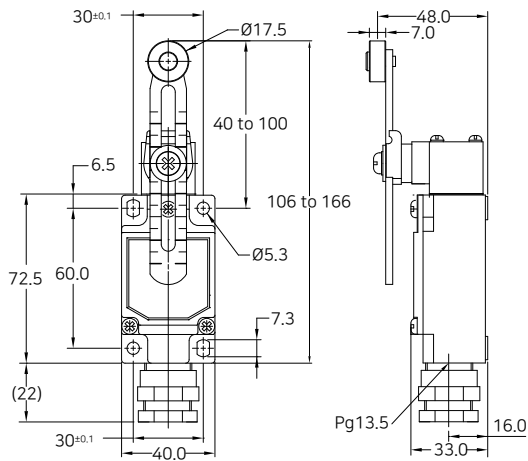

KLL-A-L4

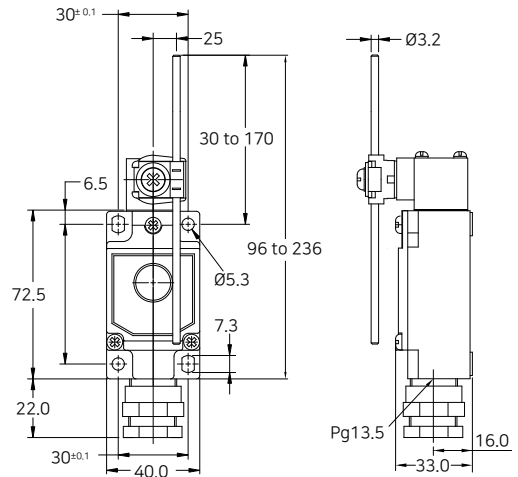

Limit Switch

KL Series

Dimension

unit : mm

KLM-A-P1

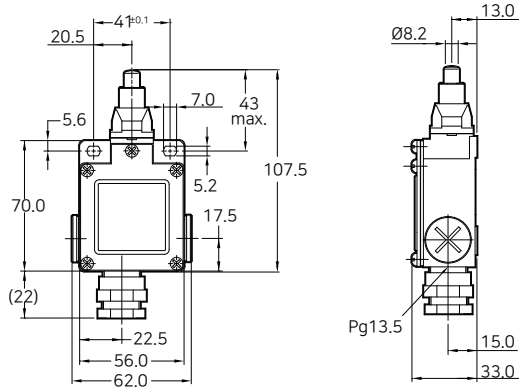

KLM-A-P2

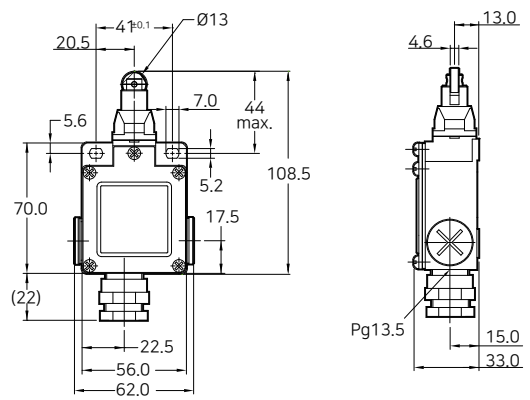

KLM-A-L1

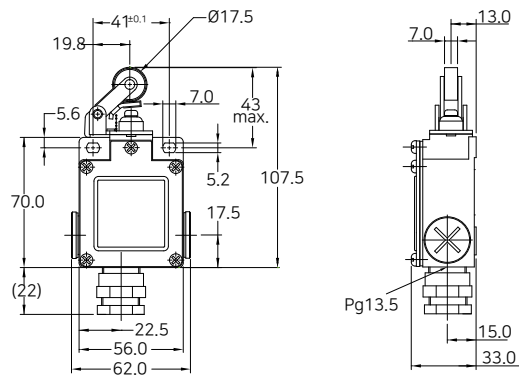

KLM-A-L2

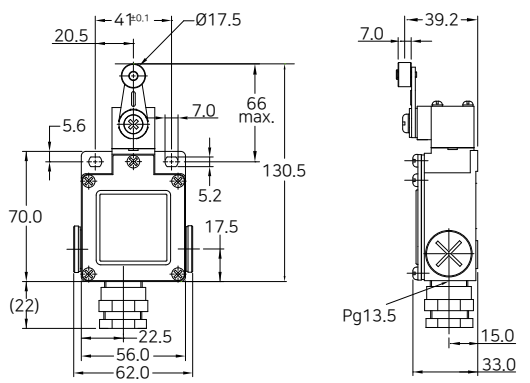

KLL-A-L3

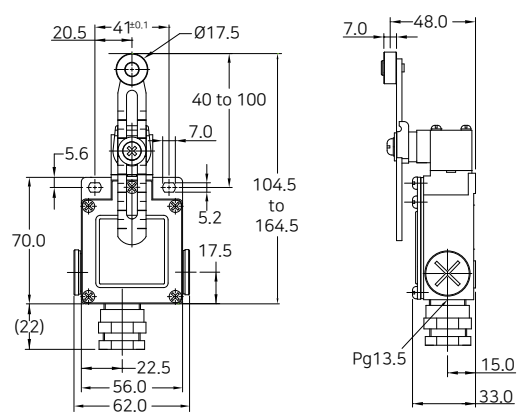

KLL-A-L4

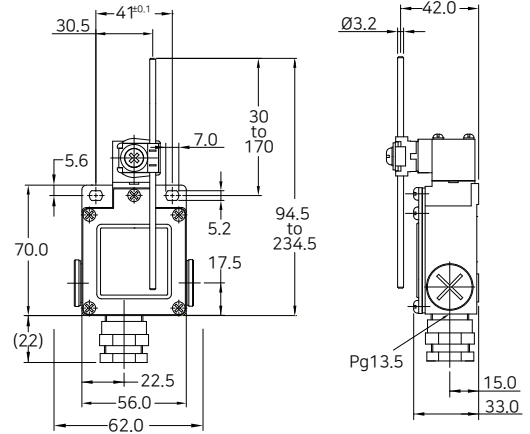

User guide

- Roller lever operating position adjustment

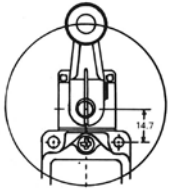

Loosen the bolt on the side of the roller lever, and adjust the angle.

- Selection of the head block direction

Roller Lever type

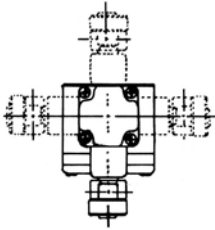

Plunger

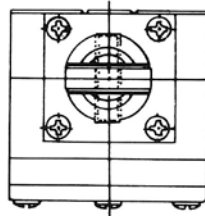

Loosen four bolts, and assemble the product in the desired direction. Pay attention to the plunger direction.

- Inside of the roller lever

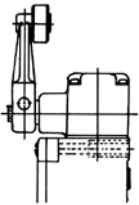

- Rear of the roller lever

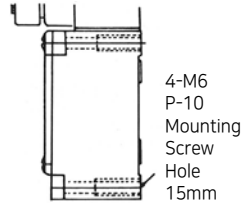

- Adjustment of the lever

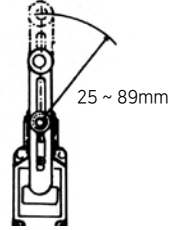

- Lever Type T.T.P

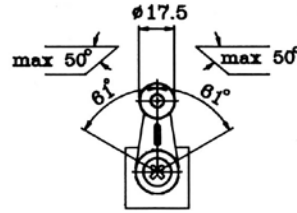

L2 Type

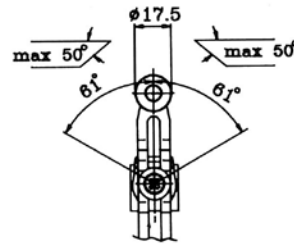

L3 Type

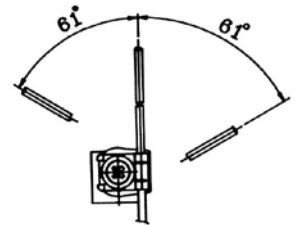

L4 Type

Attachment Processing Drawing

KLM Type

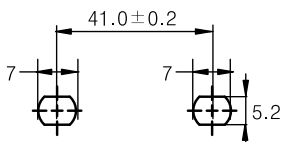

KLL Type

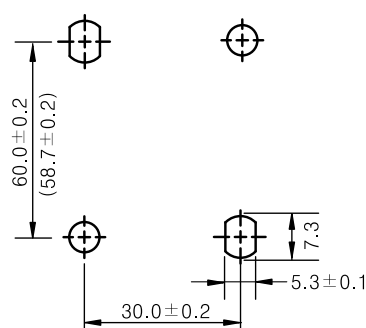

KLS Type

