

M16 Series



Features

Lighting unit

- Round button surface
- Clear light emission with diffusible lens and high-brightness LED
- Semi-permanent life
- Diverse colors (R, G, Y, B, W)
- Recordable built-in name plate

Protective front structure

- Dustproof and waterproof
- P65

Color Ring

- Diverse colors
- Four colors basically provided (R, G, A, V)
- Easy ring replacement

Body

- POM material
- Strong durability and oil resistance

Anti-loosening washer and fixing ring

- Firm fixing of the product after it is mounted on the panel
- Anti-loosening structure design against vibration and impact

Contact

- Modulized contact (1a+1b)
Additional setting (3a+3b) available.
Easy replacement.
- Snap action type (long life guaranteed)
- 24k gold-plated contact
- Excellent contact reliability (suitable for microcurrent conduction)

24k gold-plated lighting unit

24k gold-plated terminal

- Prevention of corrosion and discoloration
- Easy use of the tab terminal (#110) and soldering

Easy disassembly, assembly and replacement

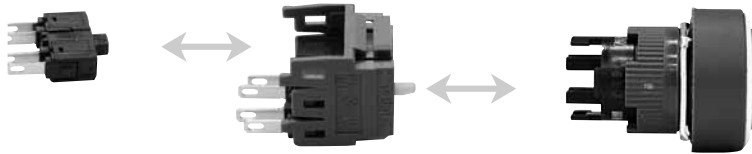

Diverse and easily replaced color rings

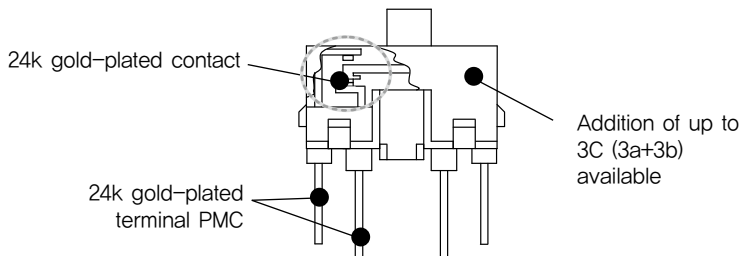

Contact block (1a+1b), product name: FCB

Push Button & Signalling Device

Ø8,10,12 Control Switch

Ø16 Control Switch

Ø22,25,30 Control Switch

Cam Switch

BOX Switch

Main Switch

Power Push Button Switch

Assembly Square Lamp

Signal Tower

Warning Light & Siren

Select Code

M16 - ① ② ③ ④ ⑤ ⑥ - ⑦ ⑧

M16	
Model	KACON Ø16 Control Switch

①	
Description	1 : Pilot Lamp
	2 : Release
	3 : Pressed down
	4 : 2step Selector
	5 : 3step Selector
	6 : 2step Key
	7 : 3step Key

②	
Appearance of the Control Part	1 : Roustep
	2 : Square
	7 : LED Roustep
	8 : LED Square

③	
Contact Structure	0 : No Contact
	1 : 1a+1b (Basic)
	2 : 2a+2b
	3 : 3a+3b

④ ⑤		
Color	LENS	RING
	K : Selector, Key	B : (Blue)
	R : (Red)	G : (Green)
	G : (Green)	A : (Amber)
	Y : (Yellow)	V : (Violet)
	W : (White)	R : (Red)
	B : (Blue)	T : (Translucency)
	M : (Smoke)	W : (White)
	C : (Clear)	Y : (Yellow)

⑥	
Regular Voltage	6VDC
	12VDC
	24VDC
	220VAC
	None : No Voltage

⑦ ⑧	
Selector & Key	Additional Product Number

Additional Product number due to the operating types of the selector/keys

●Operating types

Description	Release types				Key dislocation position						
	manual	Auto			A	B	C	D	E	F	G
2 ^{step}											
CODE	2	0			A	B	C	D	E	F	G
3 rd											
CODE	3	7	6	1	A	B	C	D	E	F	G

※Select & Key rotation is based on the 90°

※Contacts Options

Contact block : FCB (1c Contact)

Empty block : FEB (Block)

※LED Lamp : F16-S115

※For the ring, **R|G|A|V** is provided as default.

●Code System

2 **A**

2	
Operation Type	2 : 2step phase, manual
	0 : 2step phase, auto
	3 : 3step phase, manual
	7 : 3step RIGHT SIDE AutoAuto
	6 : 3step phase, left side auto
1 : 3step phase, both sides auto	

A	
Key Dislocation position	A ~ G (7types) Note) No indication for the selector

Specification

General Specification	Regular Insulating Voltage		250VAC/DC		
	Insulation Resistance		Max 100M Ω (500VDC)		
	Contact Resistance(DEFAULT VALUE)		50m Ω		
	Dielectric Strength	Between the charging section astep the earth	Min. 2,000VAC (1Min.)		
		BETWEEN THE CHARGING SECTIONS	Min. 1,500VAC (1Min.)		
	Expected Life	Mechanical	Push Button (Release) : 1,000,000 Min. Others : 250,000 Min.		
		Electrical	Min. 100,000		
	FREQUENCY OF ON/OFF		1200 Times/hour		
	Vibration		DUAL WAVE LENGTH 0.1mm (10~55Hz)		
	Impact		OPERATION ERROR : 100‰, DURABILITY : 500‰		
	Ambient Temperature		-20 ~ +70°C (ANTI-FREEZING)		
	RELATIVE HUMIDITY		45 ~ 85%RH (at-5 ~ +40°C)		
Controlling Protection Structure		IP40 (NORMAL) / IP65 (Water/Oil Proof)			
Contacts	Contact Arrangement		Default options : 1C(1a+1b), ASTEP MORE : 2C(2a+2b), 3C(3a+3b)		
	Contact Material		Ag Alloy (24K Gold Tint)		
	Regular Insulating Voltage		250VAC		
	Regular Applicable Current		Max. 5A		
	Max. On/Off Voltage		250VAC / 110VDC		
	Regular Current Used	Resistance Load (AC12/DC12)		Istepuction Load(AC13/DC13)	
		3A	24VDC	0.7A	24VDC
		0.2A	125VDC	0.15A	125VDC
3A		110VAC	1A	110VAC	
1.5A	250VAC	0.7A	250VAC		
Min. Applicable Current		10mA 5VDC			
Lit Part	Color		Red, Green, Yellow, Blue, White		
	Appearance		Roustep, Square, Rectangular		
	Regular Current Used		24VDC, 12VDC, 6VDC, 220VAC		
	Norminal Current		15mA Approx.		
	Expected Life		50,000hrs		
	Lamp Type		LED		

* LED working 50% less than the original brightness after 50000 hours.

Push
Button &
Signalling
Device

Ø8,10,12
Control
Switch

Ø16
Control
Switch

Ø22,25,30
Control
Switch

Cam
Switch

BOX
Switch

Main
Switch

Power Push
Button
Switch





Assembly
Square
Lamp

Signal
Tower

Warning
Light &
Siren

Pilot Lamp		※For the ring, R G Y B W is provided as default.
LED		
	M16-170 4 5	M16-180 4 5

※ **4** Select Lens Color **R****G****Y****B****W**
 ※ **5** Select Ring Color **B****E****G****A****V****R****T****W****Y**

Push Button Switch		
Standard		
Release	M16-211 4 5	M16-221 4 5
Alter nate	M16-311 4 5	M16-321 4 5
LED		
Release	M16-271 4 5	M16-281 4 5
Alter nate	M16-371 4 5	M16-381 4 5

※ **4** Select Lens Color **R****G****Y****B****W**
 ※ **5** Select Ring Color **B****E****G****A****V****R****T****W****Y**



220VAC Trans

F16-T1

Selector Switch / 2step ※For the ring, **R****G****A****V** is provided as default.

2step Non-Lit		
manual Release	⊗ M16-411K [5]-2	M16-421K [5]-2
AutoRelease	⊙ M16-411K [5]-0	M16-421K [5]-0

※ The lever angle for the manual release type should be 90, while the one for the automatic release type should be 70 degrees.
 ※ [5] Select Ring Color **B****E****G****A****V****R****T****W****Y**

Selector Switch / 3step

3step Standard		
manual Release	⊗ M16-512K [5]-3	M16-522K [5]-3
Auto Release	⤴ M16-512K [5]-7	M16-522K [5]-7
	⤵ M16-512K [5]-6	M16-522K [5]-6
	⤶ M16-512K [5]-1	M16-522K [5]-1
	⤷ M16-512K [5]-1	M16-522K [5]-1









※ The lever angle for the manual release type should be 90, while the one for the automatic release type should be 70 degrees.
 ※The default for the contact point is 2c.
 ※ [5] Select Ring Color **B****E****G****A****V****R****T****W****Y**

※Lever operation modes

Description	Release types				Code	Operation Mode
	manual	Auto				
2step	⊗	⊙			2	2step phase, manual
CODE	2	0			0	2step phase, auto
3step	⤴	⤵	⤶	⤷	3	3step phase, manua
CODE	3	7	6	1	7	3step phase, right side auto
					6	3step phase, left side auto
					1	3step phase, both sides auto

- Push Button & Signalling Device
- Ø8,10,12 Control Switch
- Ø16 Control Switch
- Ø22,25,30 Control Switch
- Cam Switch
- BOX Switch
- Main Switch
- Power Push Button Switch
- Assembly Square Lamp
- Signal Tower
- Warning Light & Siren

Key Switch/ 2^{step}





















2step		Dislocation position		
manual Release			M16-611K[5]-2A	M16-621K[5]-2A
			M16-611K[5]-2B	M16-621K[5]-2B
			M16-611K[5]-2D	M16-621K[5]-2D
Auto Release			M16-611K[5]-0A	M16-621K[5]-0A

※ The lever angle for the manual release type should be 90, while the one for the automatic release type should be 70 degrees.
Automatic release type should be 70 degrees.

※ [5] Select Ring Color **B E G A V R T W Y**

Key Switch/ 3step

※For the ring, **R G A V** is provided as default.

3step		Dislocation position		
manual Release			M16-712K[5]-3A	M16-722K[5]-3A
			M16-712K[5]-3B	M16-722K[5]-3B
			M16-712K[5]-3C	M16-722K[5]-3C
			M16-712K[5]-3D	M16-722K[5]-3D
			M16-712K[5]-3E	M16-722K[5]-3E
			M16-712K[5]-3F	M16-722K[5]-3F
			M16-712K[5]-3G	M16-722K[5]-3G
Auto Release			M16-712K[5]-7A	M16-722K[5]-7A
			M16-712K[5]-7E	M16-722K[5]-7E
			M16-712K[5]-7G	M16-722K[5]-7G
			M16-712K[5]-6D	M16-722K[5]-6D
			M16-712K[5]-6E	M16-722K[5]-6E
			M16-712K[5]-6F	M16-722K[5]-6F
		M16-712K[5]-1E	M16-722K[5]-1E	

※The key switch is not water proof.

※ [5] Select Ring Color **B E G A V R T W Y**

※Key operation mode

S/S Operation Mode		Key release	Left	Left/Right	Left/Center/Right	Right	Center	Center/Right	Center/Left
		CODE	A	B	C	D	E	F	G
2step	manual	2	○	○		●			
	Auto	0	○						
3step	manual	3	●	●	○	●	○	●	●
	right side auto	7	●				●		●
	left side auto	6				●	●	●	
	both sides auto	1					○		

※●for products to be released

Exterior Dimension Diagram

Unit : mm

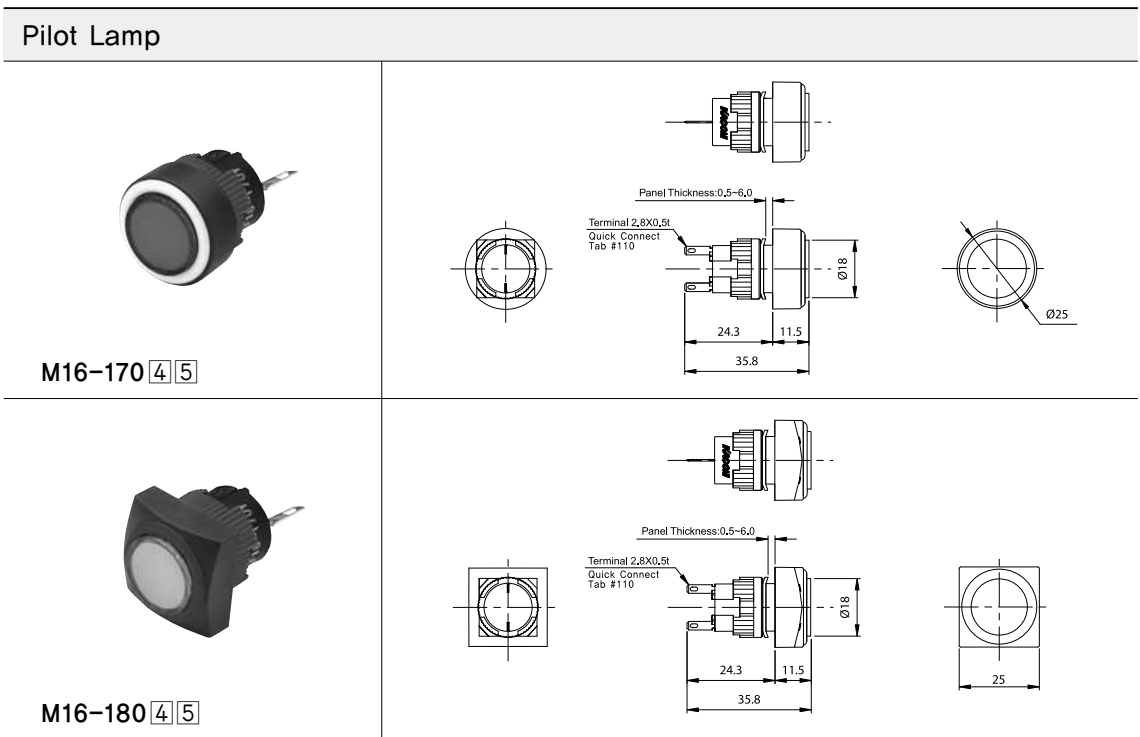

- Push Button & Signalling Device
- Ø8,10,12 Control Switch
- Ø16 Control Switch
- Ø22,25,30 Control Switch
- Cam Switch
- BOX Switch
- Main Switch
- Power Push Button Switch
- Assembly Square Lamp
- Signal Tower
- Warning Light & Siren

Push Button Switch



M16-211 4 5
 M16-311 4 5
 M16-271 4 5
 M16-371 4 5

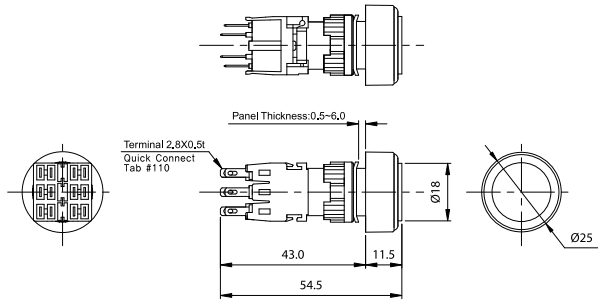

M16-221 4 5
 M16-321 4 5
 M16-281 4 5
 M16-381 4 5

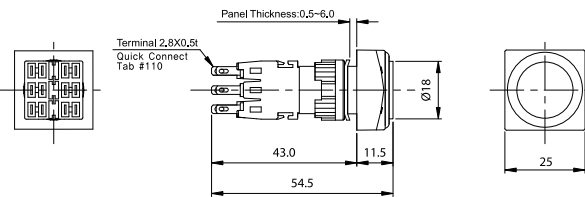

Selector Switch



M16-411K 5
 M16-512K 5

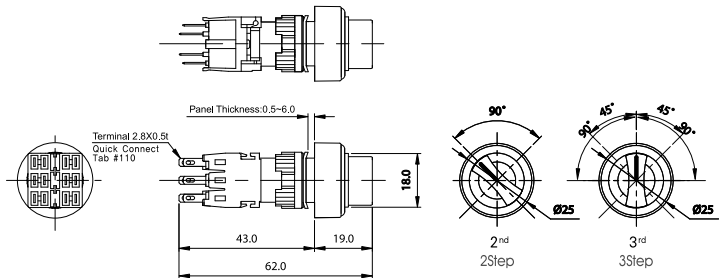

M16-421K 5
 M16-522K 5

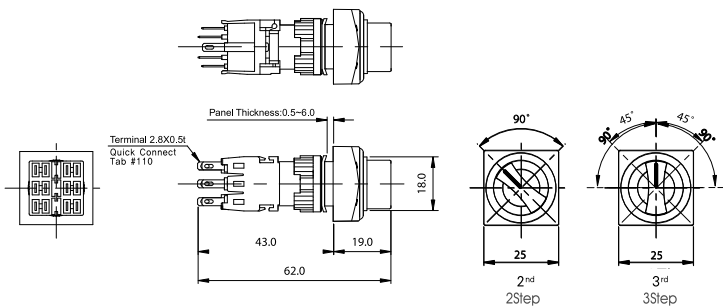

Key Switch



M16-611K 5
M16-712K 5

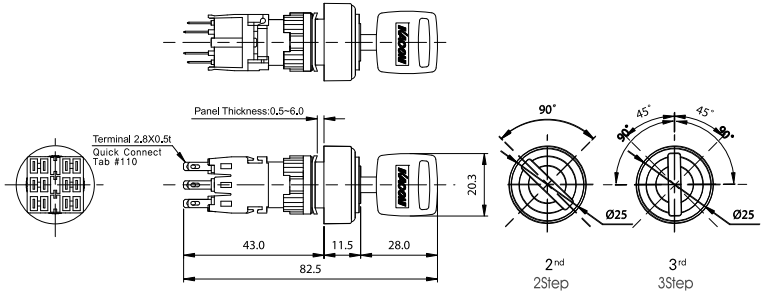

M16-621K 5
M16-722K 5

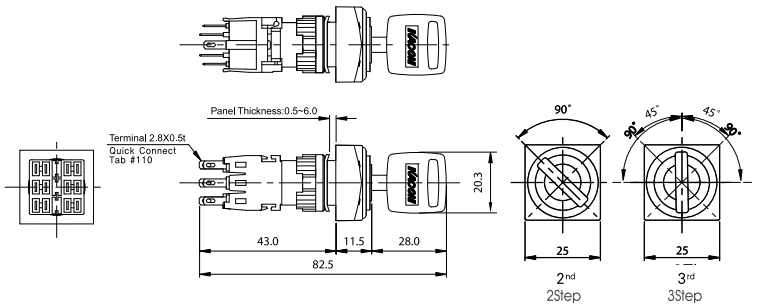

Push Button & Signalling Device

Ø8,10,12 Control Switch

Ø16 Control Switch

Ø22,25,30 Control Switch

Cam Switch

BOX Switch

Main Switch

Power Push Button Switch

Assembly Square Lamp

Signal Tower

Warning Light & Siren



Options

Safety Guard



K16-G1

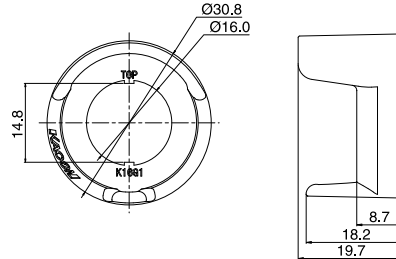

K16-G2

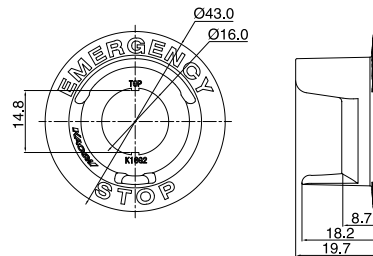

LED



6VDC
12VDC
24VDC

※ Color R G Y B W , () should use lamp's regular voltage.

※ There is a current limiting resistance installed inside the LED, making it durable for semi forever.

Note) If the power source is not of stabilized voltage, the life span of the Led can be compromised. Be careful in choosing the power source.

F16-S115 ()

Ø16 Hole Cover



K16-S117

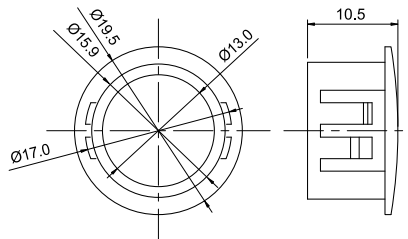

※The advantage here is that, by using K16-S117, it is possible to have back up Ø1

Fastening Tool for the Fixture Ring



K16-W1

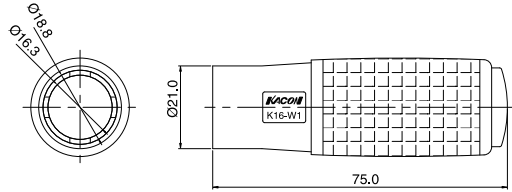

※ This is used for mounting the product on the panel.
 K16-W1 has an excellent tightening power, astep is used to fix the product on the panel without applying too much force. Note that applying the excessive force may damage the product.

Contact Block(1a+1b)	Empty Block	Terminal Protection Cover
<p>FCB</p>	<p>FCB</p>	<p>F16-S116</p>

Push Button & Signalling Device

Ø8,10,12 Control Switch

Ø16 Control Switch

Ø22,25,30 Control Switch

Cam Switch

BOX Switch

Main Switch

Power Push Button Switch

Assembly Square Lamp

Signal Tower

Warning Light & Siren

Pre-Caution

1. How to connect the wires

1) Soldering

- As for the soldering iron, use ones with the current consumption of 30W or below.
- In case using a soldering iron of which the current consumption is 30W, do not take longer than 5 secosteps for a connection. Do not exceed 10 secosteps per connection when using a soldering iron with 20W current consumption.

2) Tab Terminal

- Please use the #110 Tab Terminal

3) Connectable wires

- Single Core : Max. $\varnothing 0.8\text{mm}$
- Multi Core : Max. 0.75mm^2

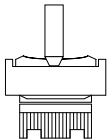

2. Installation astep Replacement of the buttons astep LEDs on the front

1) Button : Push out the button assembly with a driver by pushing into the groove on the side of the button. (In case inserting a button, push until you hear a click soustep.)

2) LED : Use tools such as a pleyer to pull it out. The assembly can be done in the reverse order of disassembly.

3. How to mount the product on the panel

- 1) Press down the projections on both sides with two fingers, astep the assembly can be easily removed from the control part.
- 2) The control part astep the contact modules have polarity. So be careful when putting them back in.
- 3) Detach the fixture ring astep the spin-stopper from the control part.
- 4) Push the control part back in the panel. The assembly is in reverse order of disassembly.
- 5) To fasten the fixture ring firmly, use K16-W1.

4. How to install astep replace the contact blocks.

- 1) Spread open the 4 projections on both side of the contact module to detach it from the block.
- 2) For assembly, push in the contact block into the gap in the contact block astep push it to hear a click soustep, which means the part is in place.(In this case, please make sure both sides are tightly locked.)
- 3) Upto three contact blocks (3a+3b) can be mounted.

5. When using a $\varnothing 16$ small control switch as the power switch for the control unit, please follow the following instruction for longer product life span astep reliability.

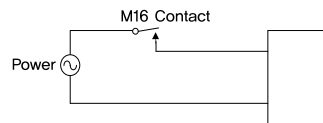

(X)

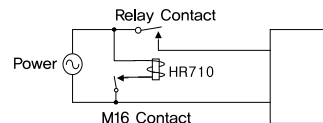

(O)

6. If you are using a DC power source which is regulated from an AC source, the ripple of the DC power source should be within 10%. If the power source does not have a stable voltage, the life span of the LED will be considerably shortened.

7. Do not use excessive force or strike the products, which could cause damages.(Driving torque for fixing panels $0.6\sim 1\text{N}\cdot\text{m}$ or lower)

8. When soldering on the terminal for wiring, please follow the instructions on the working time astep applicable temperature. If the specified criteria are exceeded, damages or thermal distortion of the product can happen.

Panel Cut-Out

Roustep/Square

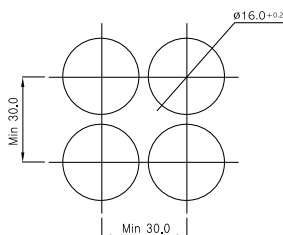

Note) 1. When processing the panels, consider the usability by the operator when deciding the distance between the holes.

2. The dimension of the hole should be $\varnothing 20.0\pm 0.2$. (If the diameter of the hole is larger than the specified value above, the product may not operate properly.)

3. When using a protection guard, please reconfigure the distances between the holes.

4. In case of the lever switches, the distances between the holes during the panel processing has some differences among them, be careful about this.

The terminal arrangement of the product

- The figure on the right shows the terminal arrangement as step internal switch circuit when the product bottom is viewed from the front.
- The factory setting is the contact block 1C (1a+1b), as step blocks can be added up to 3C (3a+3b).
- As for the selector as step key switch, two- as step three-stage switches have different ON/OFF operating points. Refer to the following table.

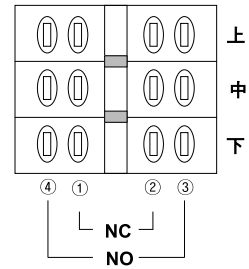

Contact Operation (Selector / Key Switch)

Types	Location of the Contacts	1C(1a+1b)	2C(2a+2b)	3C(3a+3b)
<p>2^{step}</p>	High	*		
	Middle		*	
	Low	*		
<p>3^{step}</p>	High			
	Middle			
	Low			

Push Button & Signalling Device

Ø8,10,12 Control Switch

Ø16 Control Switch

Ø22,25,30 Control Switch

Cam Switch

BOX Switch

Main Switch

Power Push Button Switch

Assembly Square Lamp

Signal Tower

Warning Light & Siren