

SA3 series

Advanced Closed Loop
Communication Inverter



Model		kW (HP)	0.75 (1)	1.5 (2)	2.2 (3)	3.7 (5)	5.5 (7.5)	7.5 (10)	11 (15)	15 (20)	18.5 (25)	22 (30)	30 (40)	37 (50)	45 (60)	55 (75)	75 (100)	90 (120)	110 (150)	132 (175)	160 (215)	185 (250)	220 (300)	250 (335)	280 (375)	315 (420)	355 (475)		
SA3	S A 3 - 3 phase 023 - 220V	150%60s	[Performance bar]																										
		200%3s	[Performance bar]																										
	S A 3 - 3 phase 043 - 440V	150%60s	[Performance bar]																										
		200%3s	[Performance bar]																										

Product Features

High Performance Vector Control Technology

- Vector control and Sensorless vector control.
- High starting torque: Sensorless vector control (SVC) 150% 0.3Hz, and closed-loop vector control(FOC + PG) 180% 0Hz.

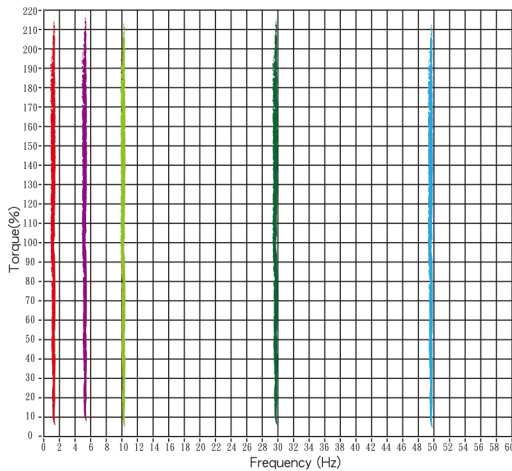

High Response Performance

- Speed accuracy: less than 1% with 0 to 100% load variation.
- For applications with sudden load changes such as cranes and metal processing machinery.

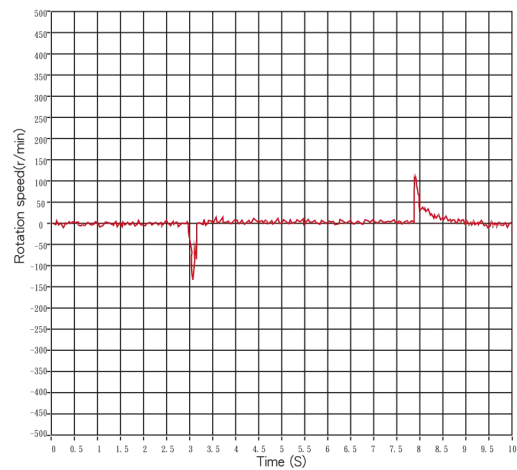

Excellent Overload Endurance

- With a current overload capability of 150% for 60 seconds and 200% for 3 seconds, the setting is suitable for handling large sudden load changes applications such as tooling machinery.

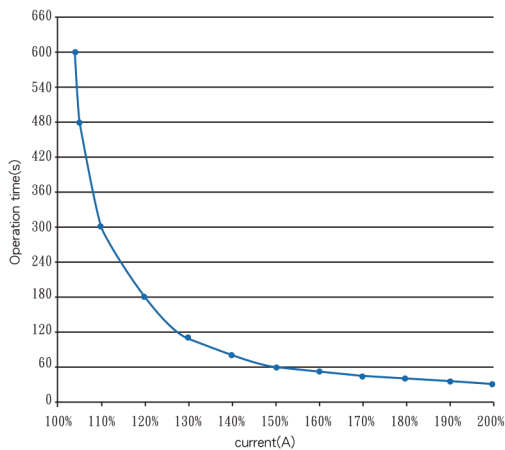

4-Quadrant Torque Control and Limits

- Parameters or analog signals can be used to simply establish limits for 4 torque items.

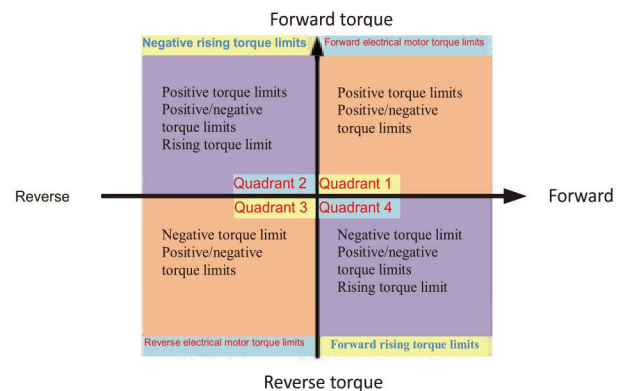

Product Features

Temporary Compensation at Low Voltage

- When temporary shut-down occurs, output frequency will be controlled to maintain DC bus voltage of the inverter to decelerate the motor.
- When power resumes, inverter will control the motor to accelerate to its previous speed.
- Applicable for machines that are not able to commence free-run while decelerating.

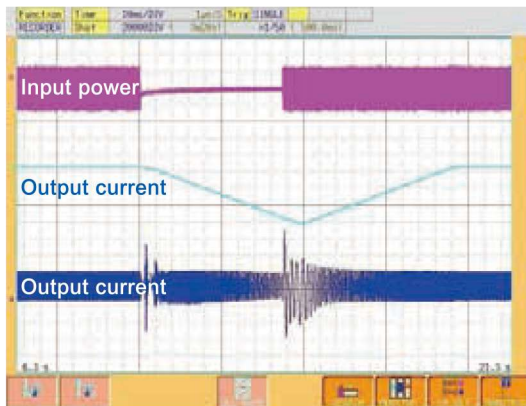

Magnetic Flux Brake

- When the motor is stopping, the magnetic flux will be transmitted to the motor coil to shorten deceleration time without relying on regenerative resistance.

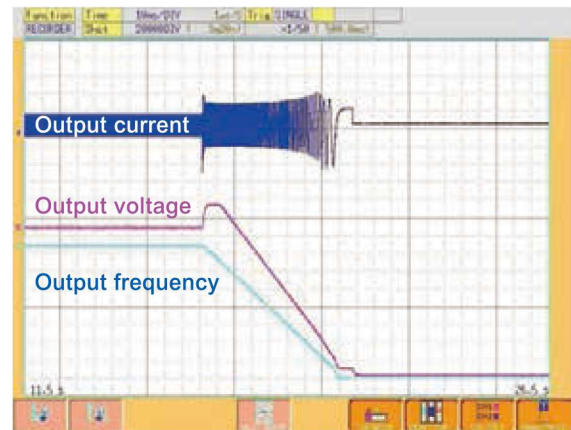

Regeneration Avoidance Functions

- By adjusting output frequency and voltage, DC bus voltage can be kept at a specified value and prevent overvoltage.

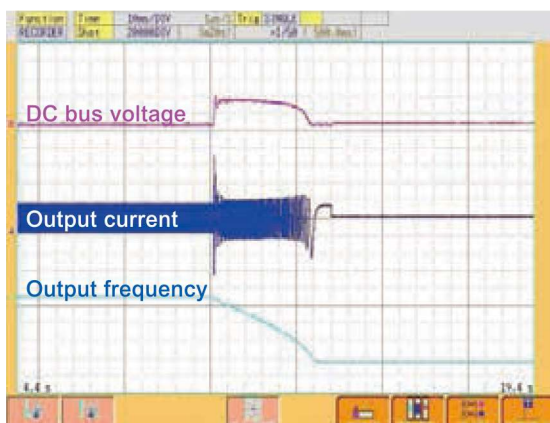

Low-noise Carrier Wave Control (Soft-PWM)

- Motor noise is controlled so that the metallic sound is transformed into a more pleasing buzz.
- Low noise operations to reduce the interference exerted upon external radio frequencies.

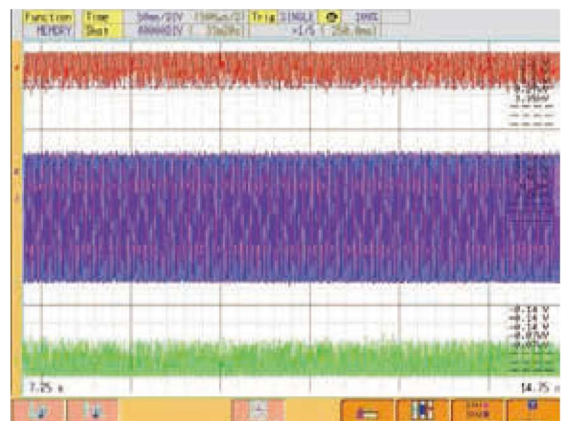



SA3

Product Features

Advanced Synchronous Motors Control Technology

- Support both induction and permanent magnet motors with open-loop control.



LCD Operation Interface

- Support 2 display styles.
- Able to simultaneously display 6 sets of operational data.
- Calendar support.
- Offer both English and Chinese language interfaces.
- Capable of storing 3 sets of parameters.
- Support shuttle settings.



Isolated Air Channel

- Fan wind channels are sealed and isolated from the heat dissipation system and electrical parts. Dust will not be able to infiltrate the interior of the machine through the fans.

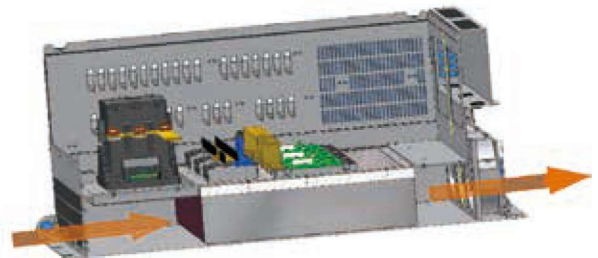

Multiple Control Modes for Various Applications

- Position / Speed / Torque / Tension control mode
- Combination mode (e.g. speed+torque) can be achieved via I/O switch.
- Advanced position control functions: Homing commands, zero speed, Pr/Pt mode(with optional PG cards).
- Support open-loop tension control, feeding disruption inspection and automatic spool replacement functions.

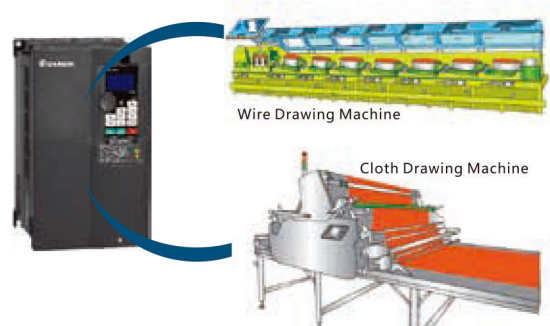

Product Features

Multiple I/O Terminals

- Include 10 sets of multi-functional combinational logic input terminals (with high-speed pulse inputs *1)
- Include 5 sets of multi-functional combinational output terminals (including electric relay output *2, transistor output *2, and high-speed pulse output *1).
- Include 3 sets of analog input signals (with -10~+10V*1 and 4~20mA/0~10V*2).
- Include 2 sets of analog output signals (0~20mA/0~10V*2).
- 1 set of safety switch (S1~SC).



Built-in PLC Functions

- Provide PLC programming software, easy for editing.
- Applicable for programming small number of points, and support multiple functions.

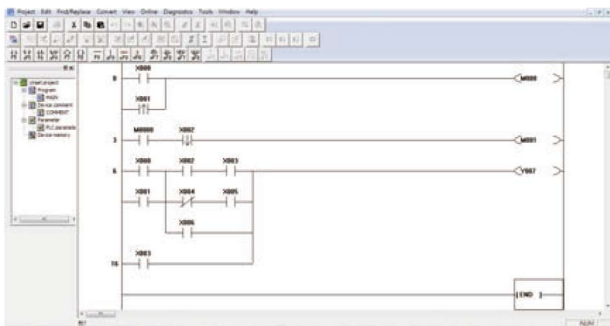

Item	SA3 PLC functions	
Programming Language	Ladder diagram + Command	
Basic commands	21	
Applicable commands	14	
Processing speed	Basic commands	1 μs
	Applicable commands	10 μs
Hidden program capacity	400 steps(0-399 steps)	
I/O configuration	Input(X)	22 points(X0~X25, octal)
	Output(Y)	20 points(Y0~Y23, octal)
Supporting electric relay (M)	General	160 points, M0~M159
	Battery backed	80 points, M160~M239
Timer(T)	Special	64 points, M8000~M8063
	100ms	8 points, T0~T7, timer range: 0~6553.5 seconds
Counter(C)	8 points, C0~C7, counting range: 0~65535	
Data register	General	32 points, D0~D31
	Battery backed	16 points, D32~D47
	Special	64 points, D8000~D8063

Through-the-wall Installation Support Provided for the Entire Series

- Improve heat dissipation, reduce heat generation within the cabinet, and improve protection for the cabinet contents.

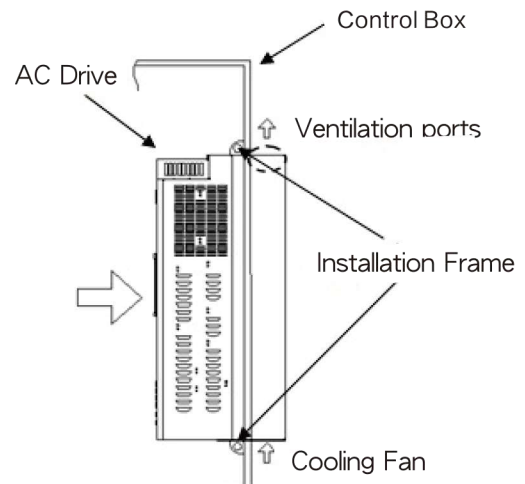

12 Sets of Alarm Records

- Complete alarm system for recording the output frequency, output current, output voltage, accumulated count of temperature increase, PN voltage, total operation time, operational status, alarm output time(only when used with PU301C).

Improved Protection

- Output phase failure protection, output short circuit protection, ground leakage protection, low voltage protection, motor overheating signal (PTC), and electrolytic capacitor life inspection.

Built-in RFI filter

- Reduce electromagnetic interference.

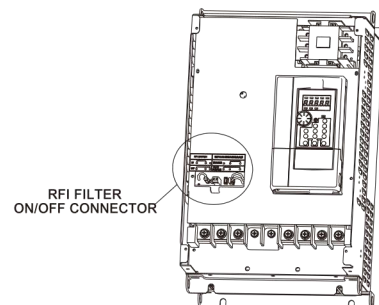



SA3

Model Identification

SA3 **043 0.75K/1.5KF** **XY**

Series	Voltage level	Capacity	Version
SA3 series	043 : three phase 440V 023 : three phase 220V	HD : 0.75kW ND : 1.5kW	None : General model -xy : Customized or specialized or region difference

Electrical Specifications

220V Three-phase Series

Frame		A				B			C		D			E		F		G		
Model SA3-023- □ -xy		075K 1.5KF	1.5K 2.2KF	2.2K 3.7KF	3.7K 5.5KF	5.5K 7.5KF	7.5K 11KF	11K 15KF	15K 18.5KF	18.5K 22KF	22K 30KF	30K 37KF	37K 45KF	45K 55KF	55K 75KF	75K 90KF	90K 110KF	110K 132KF		
Output	HD	Rated output capacity (kVA)	2	3.2	4.2	6.7	9.5	12.5	18.3	24.7	28.6	34.3	45.7	55	65	82	110	132	165	
		Rated output current (A)	5	8	11	17.5	25	33	49	65	75	90	120	145	170	215	288	346	432	
		Applicable motor capacity (HP)	1	2	3	5	7.5	10	15	20	25	30	40	50	60	75	100	120	145	
		Applicable motor capacity(kW)	0.75	1.5	2.2	3.7	5.5	7.5	11	15	18.5	22	30	37	45	55	75	90	110	
		Overload current rating	150% 60 seconds 200% 3 seconds (inverse time characteristics)																	
		Carrier frequency (kHz)	1~15kHz									1~9kHz								
	ND	Rated output capacity (kVA)	3.2	4.2	6.7	9.5	12.5	18.3	24.7	28.6	34.3	45.7	55	65	82	110	132	165	193	
		Rated output current (A)	8	11	17.5	25	33	49	65	75	90	120	145	170	215	288	346	432	506	
		Applicable motor capacity (HP)	2	3	5	7.5	10	15	20	25	30	40	50	60	75	100	120	145	175	
		Applicable motor capacity (kW)	1.5	2.2	3.7	5.5	7.5	11	15	18.5	22	30	37	45	55	75	90	110	132	
		Overload current rating	120% 60 seconds (inverse time characteristics)																	
		Carrier frequency (kHz)	1~15kHz									1~9kHz								
Maximum output voltage		Three-phase 200-240V																		
Rated power voltage		Three-phase 200-240V 50Hz / 60Hz																		
Power voltage permissible fluctuation		Three-phase 170-264V 50Hz / 60Hz																		
Power frequency permissible fluctuation		±5%																		
Power source capacity (kVA)		2.5	4.5	6.4	10	12	17	20	28	34	41	52	65	79	100	110	132	165		
Rated input current(A) (Note1)	HD	6	12	16	20	28	35	52	72	83	93	124	143	180	250	300	380	450		
	ND	12	16	20	28	35	52	72	83	93	124	142	180	250	300	380	450	520		
Cooling method		Self cooling			Forced air cooling															
Weight(kg)		3.15	3.15	3.15	3.15	6	6	6	10.6	10.6	33	33	33	42.7	42.7	56.5	89.2	90.2		

Note1:

The value of rated input current is not only affected by the power transformer, input reactor and wiring conditions but also fluctuates with the impedance on the power side.

Note:

The test conditions of rated output current, rated output capacity and inverter power consumption are:the carrier frequency (P.72) is at the set value; the inverter output voltage is at 220V; the output frequency is at 60Hz, and the ambient temperature is 40°C.

Electrical Specifications

440 V Three-phase Series

Frame		A					B			C			D	
Model SA3-043-□-xy		0.75K 1.5KF	1.5K 2.2KF	2.2K 3.7KF	3.7K 5.5KF	5.5K 7.5KF	7.5K 11KF	11K 15KF	15K 18.5KF	18.5K 22KF	22K 30KF	30K 37KF	37K 45KF	
Output	HD	Rated output capacity (kVA)	2	3	4.6	6.9	10	14	18	25	29	34	46	56
		Rated output current (A)	3.0	4.2	6	9	12	17	24	32	38	45	60	73
		Applicable motor capacity (HP)	1	2	3	5	7.5	10	15	20	25	30	40	50
		Applicable motor capacity(kW)	0.75	1.5	2.2	3.7	5.5	7.5	11	15	18.5	22	30	37
	Overload current rating	150% 60 seconds 200% 3 seconds (inverse time characteristics)												
	Carrier frequency (kHz)	1~15kHz												
	ND	Rated output capacity (kVA)	3	4.6	6.9	10	14	18	25	29	34	46	56	69
		Rated output current (A)	4.2	6	9	12	17	24	32	38	45	60	73	91
Applicable motor capacity (HP)		2	3	5	7.5	10	15	20	25	30	40	50	60	
Applicable motor capacity (kW)		1.5	2.2	3.7	5.5	7.5	11	15	18.5	22	30	37	45	
Overload current rating	120% 60 seconds (inverse time characteristics)													
Carrier frequency (kHz)	1~15kHz													
Maximum output voltage	Three-phase 380-480V													
Power supply	Rated power voltage	Three-phase 380-480V 50Hz / 60Hz												
	Power voltage permissible fluctuation	Three-phase 342-528V 50Hz / 60Hz												
	Power frequency permissible fluctuation	±5%												
	Power source capacity (kVA)	2.5	4.5	6.9	10.4	11.5	16	20	27	32	41	52	65	
	Rated input current(A) (Note1)	HD	4.0	5.9	8.7	14	17	20	26	35	40	47	63	74
	ND	5.9	8.7	14	17	20	26	35	40	47	63	74	101	
Cooling method	Self cooling		Forced air cooling											
Weight(kg)	3.15		3.15	3.15	3.15	3.15	6	6	6	9.8	9.8	9.8	33	

Frame		D			E		F	G			H			
Model SA3-043-□-xy		45K 55KF	55K 75KF	75K 90KF	90K 110KF	110K 132KF	132K 160KF	160K 185KF	185K 220KF	220K 250KF	250K 280KF	280K 315KF	315K 355KF	
Output	HD	Rated output capacity (kVA)	69	84	114	137	168	198	236	295	367	402	438	491
		Rated output current (A)	91	110	150	180	220	260	310	340	425	480	530	620
		Applicable motor capacity (HP)	60	75	100	120	150	175	215	250	300	335	375	420
		Applicable motor capacity(kW)	45	55	75	90	110	132	160	185	220	250	280	315
	Overload current rating	150% 60 seconds 200% 3seconds (inverse time characteristics)												
	Carrier frequency (kHz)	1~9kHz												
	ND	Rated output capacity (kVA)	84	114	137	168	198	236	295	367	402	438	491	544
		Rated output current (A)	110	150	180	220	260	310	340	425	480	530	620	683
Applicable motor capacity (HP)		75	100	120	150	175	215	250	300	335	375	420	475	
Applicable motor capacity (kW)		55	75	90	110	132	160	185	220	250	280	315	355	
Overload current rating	120% 60 seconds (inverse time characteristics)													
Carrier frequency (kHz)	1~9kHz													
Maximum output voltage	Three-phase 380-480V													
Power supply	Rated power voltage	Three-phase 380-480V 50Hz / 60Hz												
	Power voltage permissible fluctuation	Three-phase 342-528V 50Hz / 60Hz												
	Power frequency permissible fluctuation	±5%												
	Power source capacity (kVA)	79	100	110	137	165	198	247	295	367	402	438	491	
	Rated input current(A) (Note1)	HD	101	114	157	167	207	240	300	380	400	500	550	650
	ND	114	157	167	207	240	300	380	400	500	550	650	700	
Cooling method	Self cooling		Forced air cooling											
Weight(kg)	33		33	33	42.7	42.7	56.5	84	84	84	84	123	123	

Note1:

The value of rated input current is not only affected by the power transformer, input reactor and wiring conditions but also fluctuates with the impedance on the power side.

Note:

The test conditions of rated output current, rated output capacity and inverter power consumption are:the carrier frequency (P.72) is at the set value; the inverter output voltage is at 220V; the output frequency is at 60Hz, and the ambient temperature is 40°C.



SA3

Common Specifications

Control method		SVPWM control, V/F control, close-loop V/F control (VF+PG), general flux vector control, sensorless vector control (SVC), close-loop vector control (FOC+PG), torque control (TQC+PG).
Output frequency range		0~599.00Hz
Frequency setting resolution	Digital setting	The resolution is 0.01Hz.
	Analog setting	0.01Hz/60Hz (terminal 2: -10 ~ +10V / 13bit) 0.015Hz/60Hz (terminal 2: 0 ~ ±10V / 12bit; terminal 3: 0~10V, 4-20mA / 12bit) 0.03Hz/60Hz (terminal 2, 3; 0 ~ 5V / 11bit) 0.06Hz/60Hz (terminal 4: 0~10V, 4-20mA /10bit) 0.12Hz/60Hz (terminal 4: 0 ~ 5V /9bit)
Output frequency accuracy	Digital setting	Maximum target frequency ± 0.01%.
	Analog setting	Maximum target frequency ± 0.1%.
Speed control range		IM: When SVC, 1:200; when FOC+PG, 1:1000. PM: When SVC, 1:20; when FOC+PG, 1:1000.
Start torque		150% 0.3Hz (SVC), 180% 0Hz (FOC+PG).
V/F characteristics		Constant torque curve, variable torque curve, five-point curve, VF separation
Acceleration / deceleration curve characteristics		Linear acceleration / deceleration curve, S shape acceleration / deceleration curve 1 & 2 & 3
Drive motor		Induction motor (IM), permanent magnet motor (SPM, IPM)
Stalling protection		The stalling protection level can be set to 0~400% (06-01(P.22)). The default value is 150%.
Target frequency setting		Keypad setting, DC 0~5V/10V signal, DC -10~+10V signal, DC 4~20 mA signal, multi-speed stage level setting, communication setting, HDI setting.
PID control		Please refer to 08-00~08-01、08-04~08-14 / P.170~P.182 in chapter 4.
Built-in simple PLC		Supports 21 basic instructions and 14 application instructions, including PC editing software;
Keypad	Operation monitoring	Output frequency, output current, output voltage, PN voltage, output torque, electronic thermal accumulation rate, temperature rising accumulation rate, output power, analog value input signal, digital input and output terminal status...; alarm history 12 groups at most, the last group of alarm message is recorded.
	LED indicator (10)	Forward rotation indicator, reverse rotation indicator, frequency monitoring indicator, voltage monitoring indicator, current monitoring indicator, NET indicator, PU control indicator, EXT indicator, PLC indicator and MON monitoring indicator.
Communication function		RS-485 communication, can select Shihlin/Modbus communication protocol, communication speed up to 115200bps, built-in CanOpen protocol (with CP301 expansion card), double RJ-45 connectors (the connector can also be connected to keypad)
Protection mechanism / alarm function		Output short circuit protection, Over-current protection, over-voltage protection, under-voltage protection, motor over-heat protection (06-00(P.9)), IGBT module over-heat protection, communication abnormality protection, PTC temperature protection etc, electrolytic capacitor overheat, input and output phase failure, to-earth (ground) leakage currents protection, circuit error detection...
Environment	Ambient temperature	Heavy duty : -10 ~ +50°C (non-freezing), Light duty : -10 ~ +40°C (non-freezing), please refer to 3.4.5 Class of protection and operation temperature for details.
	Ambient humidity	Below 90%Rh (non-condensing).
	Storage temperature	-20 ~ +65°C
	Surrounding environment	Indoor, no corrosive gas, no flammable gas, no flammable dust.
	Altitude	Altitude below 3000 meters, when altitude is above 1,000 m, derate the rated current 2% per 100 m Note 1: According to the safety regulation EN61800-5-1, which is required to declare in CE certification, this series of inverters can be installed in an environment of over-voltage class II when the altitude is less than 3000m. When the altitude is less than 2000m, can be installed in harsher conditions that meet the requirements of over-voltage class III.
	Vibration	Vibration below 5.9m/s ² (0.6G)
	Grade of protection	Frame A, B, C, IP20 / NEMA TYPE 1, Frame D and above IP00 / UL OPEN TYPE (optional IP20 accessories can be added).
	The degree of environmental pollution	2
Class of protection		Class I
International certification		CE

Wiring Diagram

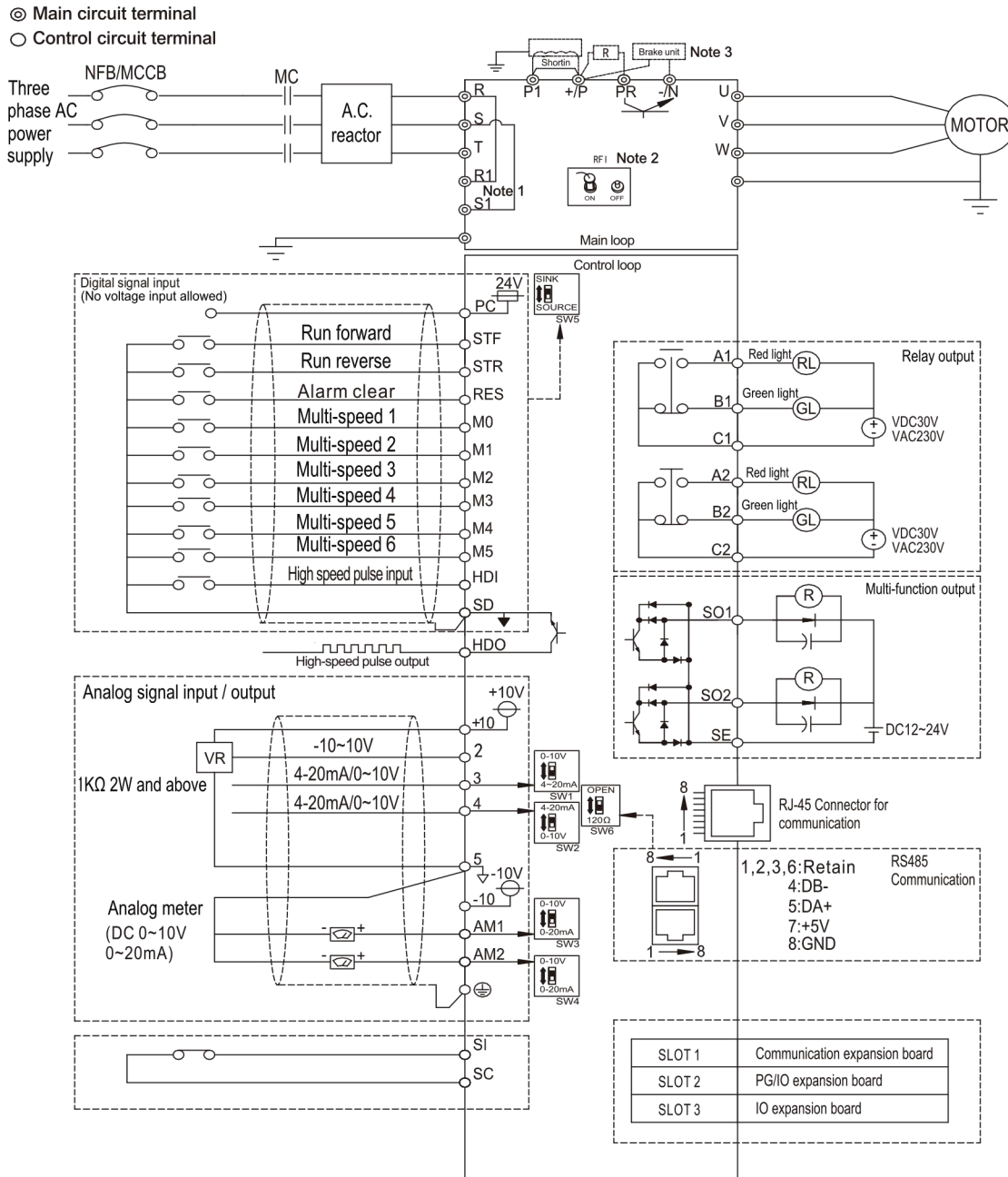

NOTE

- R1 S1 terminal is only for frame D-H.
- The connection of braking resistor between +/P and PR is only for frame A, B and C. For frame D and above, please connect a braking unit between +/P and -N.
- The DC reactor between + / P and P1 is optional, please short + / P and P1 when DC reactor is not used.



SA3

Dimensions

Unit : mm

Frame A

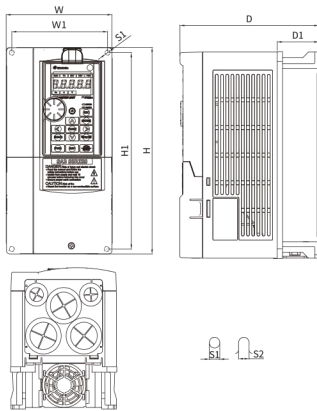

Frame A

Model type	W (mm)	W1 (mm)	H (mm)	H1 (mm)	D (mm)	D1 (mm)	S1 (mm)	S2 (mm)
SA3-043-0.75K/1.5KF	130.0	116.0	250.0	236.0	170.0	51.3	6.2	6.2
SA3-043-1.5K/2.2KF								
SA3-043-2.2K/3.7KF								
SA3-043-3.7K/5.5KF								
SA3-043-5.5K/7.5KF								
SA3-023-0.75K/1.5KF								
SA3-023-1.5K/2.2KF								
SA3-023-2.2K/3.7KF								
SA3-023-3.7K/5.5KF								

Frame B

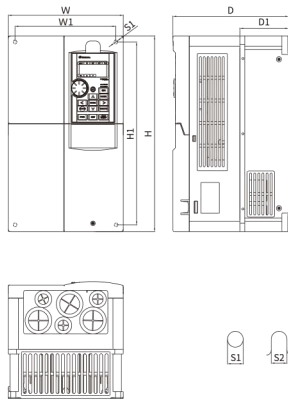

Frame B

Model type	W (mm)	W1 (mm)	H (mm)	H1 (mm)	D (mm)	D1 (mm)	S1 (mm)	S2 (mm)
SA3-043-7.5K/11KF	190.0	173.0	320.0	303.0	190.0	80.5	8.5	8.5
SA3-043-11K/15KF								
SA3-043-15K/18.5KF								
SA3-023-5.5K/7.5KF								
SA3-023-7.5K/11KF								
SA3-023-11K/15KF								

Frame C

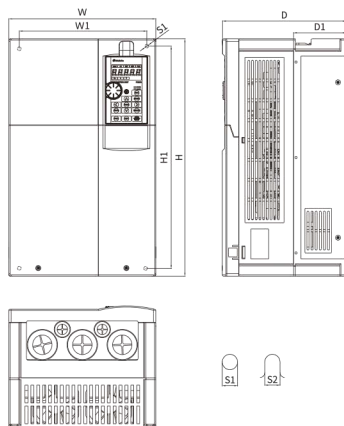

Frame C

Model type	W (mm)	W1 (mm)	H (mm)	H1 (mm)	D (mm)	D1 (mm)	S1 (mm)	S2 (mm)
SA3-043-18.5K/22KF	250.0	231.0	400.0	381.0	210.0	89.5	8.5	8.5
SA3-043-22K/30KF								
SA3-043-30K/37KF								
SA3-023-15K/18.5KF								
SA3-023-18.5K/22KF								

Dimensions

Unit : mm

Frame D

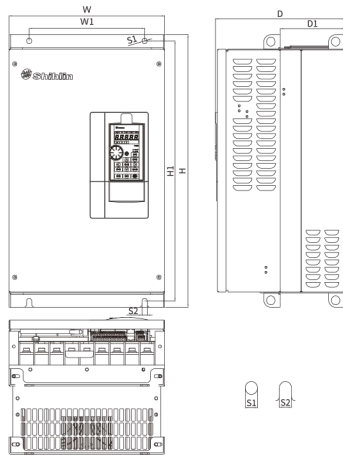

Frame D

Model type	W (mm)	W1 (mm)	H (mm)	H1 (mm)	D (mm)	D1 (mm)	S1 (mm)	S2 (mm)
SA3-043-37K/45KF	330.0	245.0	550.0	525.0	275.0	137.5	11.0	11.0
SA3-043-45K/55KF								
SA3-043-55K/75KF								
SA3-043-75K/90KF								
SA3-023-22K/30KF								
SA3-023-30K/37KF								
SA3-023-37K/45KF								

Frame E

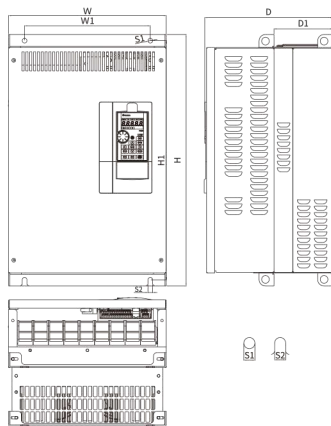

Frame E

Model type	W (mm)	W1 (mm)	H (mm)	H1 (mm)	D (mm)	D1 (mm)	S1 (mm)	S2 (mm)
SA3-043-90K/110KF	370.0	295.0	589.0	560.0	300.0	137.5	11.0	11.0
SA3-043-110K/132KF								
SA3-023-45K/55KF								
SA3-023-55K/75KF								

Frame F

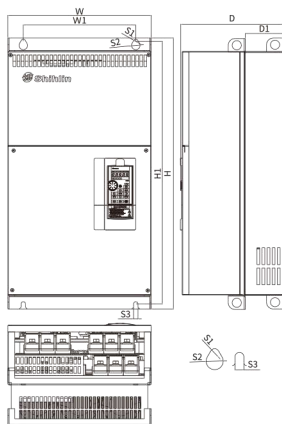

Frame F

Model type	W (mm)	W1 (mm)	H (mm)	H1 (mm)	D (mm)	D1 (mm)	S1 (mm)	S2 (mm)	S3 (mm)
SA3-043-132K/160KF	420.0	340.0	800.0	770.0	300.0	145.5	13.0	25.0	13.0
SA3-023-75K/90KF									



SA3

Dimensions

Unit : mm

Frame G

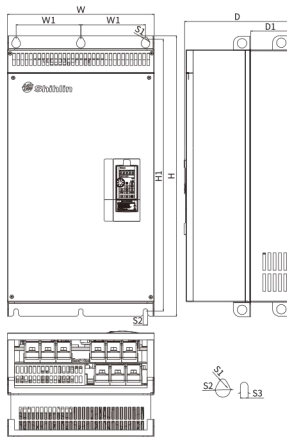

Frame G

Model type	W (mm)	W1 (mm)	H (mm)	H1 (mm)	D (mm)	D1 (mm)	S1 (mm)	S2 (mm)	S3 (mm)
SA3-043-160K/185KF	500.0	180.0	870.0	850.0	360.0	150.0	13.0	25.0	13.0
SA3-043-185K/220KF									
SA3-043-220K/250KF									
SA3-043-250K/280KF									
SA3-023-90K/110KF									
SA3-023-110K/132KF									

Frame H

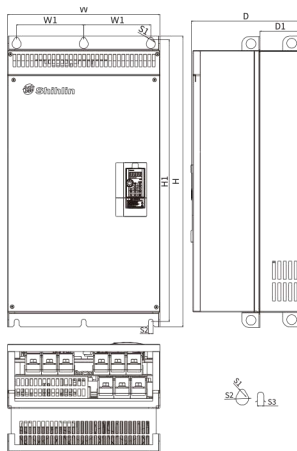

Frame H

Model type	W (mm)	W1 (mm)	H (mm)	H1 (mm)	D (mm)	D1 (mm)	S1 (mm)	S2 (mm)	S3 (mm)
SA3-043-280K/315KF	600.0	230.0	1000.0	980.0	400.0	181.5	13.0	25.0	13.0
SA3-043-315K/355KF									

Optional Accessory

Expansion Card - SF3 / SE3 / SA3 Series

PD302

Profibus communication expansion card



DN301

DeviceNet communication expansion card



CP301

CANopen communication expansion card



EP301

Ethernet communication expansion card



EB362R

I/O expansion card

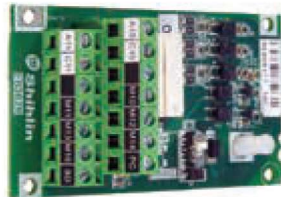

EB308R

I/O expansion card

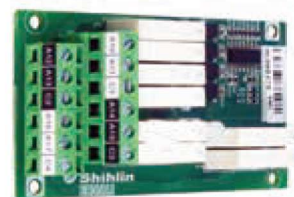

EC301-□□

EtherCAT communication expansion card

□□ SA3:A3, SE3:E3, SF3:F3



PG301C (SE3/SA3 Only)

Encoder feedback card (supports open collector type output)

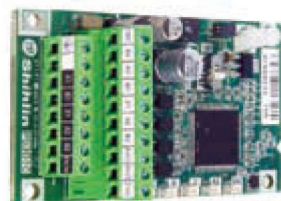

PG301L (SE3/SA3 Only)

Encoder feedback card (supports differential type output)

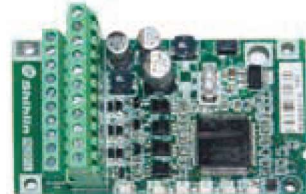

PG302L (SE3/SA3 Only)

Encoder feedback card (supports Resolver signal)



CMK301 (SE3 Only)

For installing expansion card on SE3



Optional Accessory

Keypad

PU301 (SL3/SC3/SE3/SF3/SA3)



PU301C(SA3/SF3)



PU302(SE3)



DU06 (SL3/SC3/SS2)



DU10(SS2/SC3)



DU08S (SL3/SC3/SS2)



Others

Data Cable

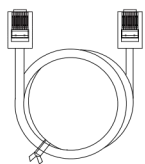

CBL1R5/03/05GT



CBL1R5/03/05/10GTN2
(SL3/SC3/SF3/SA3)

RS-485 Adapter



USB01
USB to RS-485

AC/DC Reactor



Braking Unit (BKU)

Model Identification



Series	Voltage level	Capacity	Version
BKU series	-040 : 400V -020 : 200V	37kW	None : General model -xy : Customized or specialized or region difference
		45kW	
		110kW	
		160kW	

Feature

Durable appearance , IGBT modularized, great cooling, single and multi use. wiring friendly, can be used in variety brand of VFD

Dimension

Unit : mm

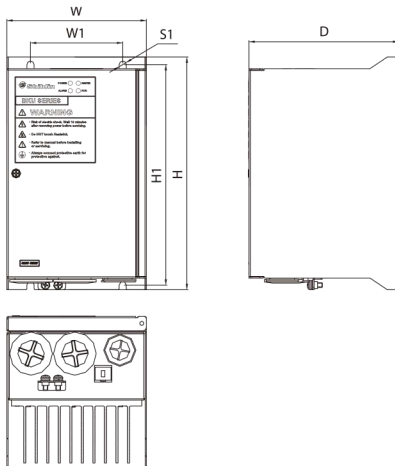

Frame A

Model type	W (mm)	W1 (mm)	H (mm)	H1 (mm)	D (mm)	S1 (mm)
BKU-020-37K	121	80	200	189.5	130	6.4
BKU-040-45K						

Frame B

Model type	W (mm)	W1 (mm)	H (mm)	H1 (mm)	D (mm)	S1 (mm)
BKU-020-110K	233.5	193.5	343	329	190	6.4
BKU-040-160K						

Braking Unit & Braking Resistor Application Table

Voltage	Motor Rating	Equivalent Braking Resistor	Braking Unit		Braking Resistor (20%ED, 125% Braking torque)	
			Model	Unit	Specification	Unit
200V	22kW	10800W 6.8Ω	BKU-020-37K	1	1200W 6.8R	9
	30kW	13500W 5Ω	BKU-020-37K	1	1500W 5R	9
	37kW	21600W 4Ω	BKU-020-37K	1	1200W 8R	18
	45kW	21600W 3.4Ω	BKU-020-37K	2	1200W 6.8R	18
	55kW	27000W 2.5Ω	BKU-020-37K	2	1500W 5R	18
	75kW	19200W 2Ω	BKU-020-37K	2	1200W 8R	16
	90kW	25000W 2R	BKU-020-110K	1	1000W 50R	25
	110kW	24000W 1.6R	BKU-020-110K	1	1200W 8R	20
400V	37kW	21600W 16Ω	BKU-040-45K	1	1200W 8R	18
	45kW	21600W 13.6Ω	BKU-040-45K	1	1200W 6.8R	18
	55kW	20000W 10Ω	BKU-040-45K	2	1000W 50R	20
	75kW	43200W 6.8Ω	BKU-040-45K	2	1200W 6.8R	36
	90kW	43200W 6.8Ω	BKU-040-45K	2	1200W 6.8R	36
	110kW	36000W 5.6Ω	BKU-040-45K	3	1000W 50R	36
	132kW	54000W 4.4Ω	BKU-040-45K	3	1200W 8R	45
	160kW	38400W 4Ω	BKU-040-160K	1	1200W 8R	32
	185kW	38400W 3.4Ω	BKU-040-160K	2	1200W 6.8R	32
	220kW	57600W 2.7Ω	BKU-040-160K	2	1200W 8R	48
	250kW	48000W 2.5Ω	BKU-040-160K	2	1500W 5R	32
	280kW	67200W 2.3Ω	BKU-040-160K	2	1200W 8R	56
	315kW	67200W 1.9Ω	BKU-040-160K	2	1200W 6.8R	56
	355kW	72000W 1.7Ω	BKU-040-160K	3	1500W 5R	48

Note: If an adjustment of ED percentage is needed, please refer to the user manual for the connections of resistors.