

FNC PM28 Series



Features

- Designed for motor feedback applications
- One period sincos signals
- Non-contact magnetic technology
- 28 mm diameter body
- Long life
- Compact dimensions

Technical data - electrical ratings

Voltage supply	7.5 - 31VDC \pm %5
Interface	4 Vpp Sine and cosine
Resolution (steps/turn) :	One per revolution

Technical data - mechanical design

Dimensions	\varnothing 28 mm
Mount Diameter	38 mm
Materials	Housing: ABS (plastic)
Magnet actuator	for integration into 6 mm shaft

Connection

Function	Color	Pin
Supply	○ White	pin 1
GND	● Yellow	pin 4
Sin	● Brown	pin 2
Cos	● Green	pin 3

Pulse Diagram

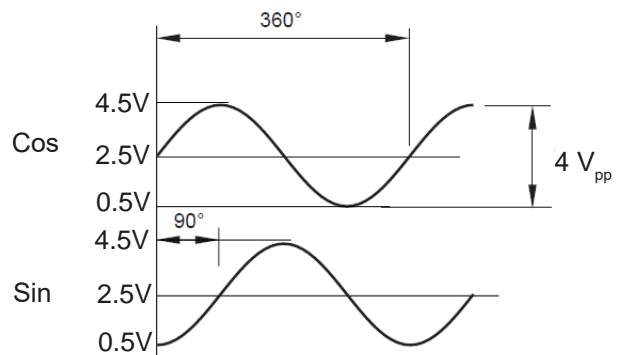

FNC PM28 Series

Mechanical Dimensions

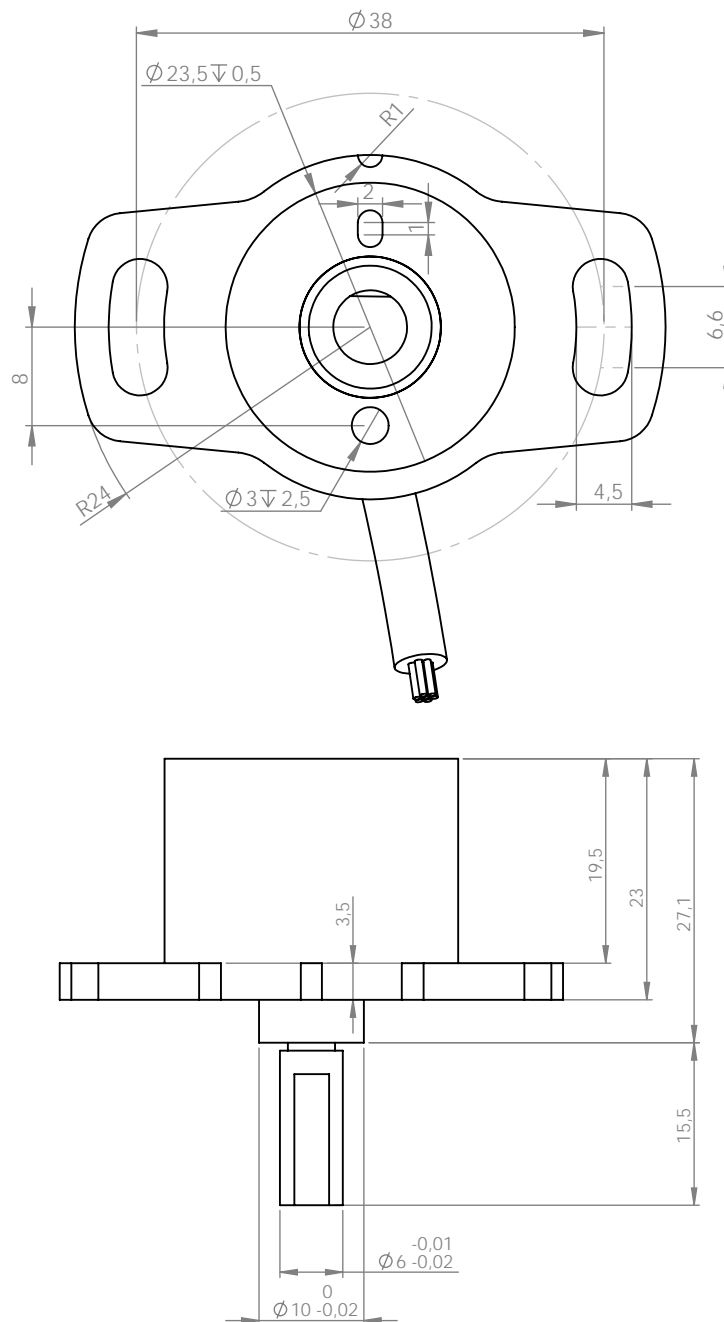

Encoder Part Number

FNC PM 28 A V0545 - R08 SCK

Material type of body

A : ABS

Output type

V0545: 0,5V - 4,5V

Conector type

SCK : Socket

Cable length

R08 : 8 cm