

Tacho analog output versus speed

Current / voltage output

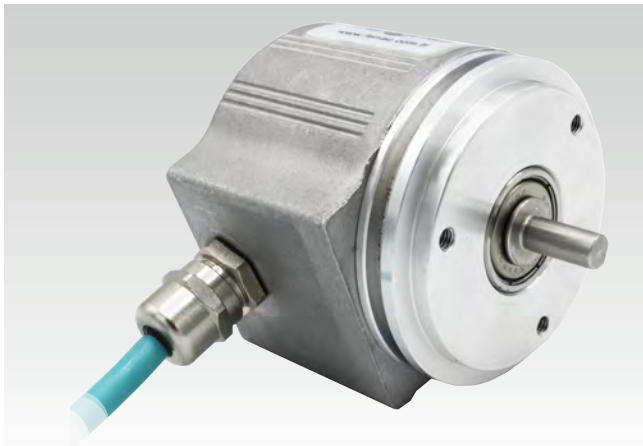

FNC Tacho 58S Series



Features

- Industry 58 mm housing
- Servo flange
- Robust mechanical and electrical construction
- Protection up to IP67
- 0-10V voltage / 4-20mA current output versus position

Technical data-electrical ratings

Voltage supply	10 - 30 VDC
Protection	Output short circuit protection. Reverse polarity protection
Consumption w/o load	≤60 mA (24 VDC)
Output signals	0 - 10 VDC voltage output 0 - 5 VDC voltage output 4 - 20 mA current output
Measuring range	up to 6000 rpm
Interference immunity	DIN EN 61000-6-2
Emitted interference	DIN EN 61000-6-4
Approval	CE

Technical data-mechanical ratings

Dimensions (flange)	Ø58 mm
Shaft loading	≤140 N axial ≤240 N radial
Protection DIN EN 60529	IP54, IP65
Operating speed	≤10,000 rpm
Starting torque	≤0.025 Nm (IP67)
Materials	Housing: aluminum Shaft: stainless steel
Shaft diameter	6, 8, 10, 12 mm (other diameters on request)
Bearings lifetime	2x10 ⁹ rev. at 100% of full rated shaft load (minimum)
Operating temperature	-20...+85°C
Storage temperature	-30°C up to +90°C
Weight approx.	250 g

Tacho analog output versus speed



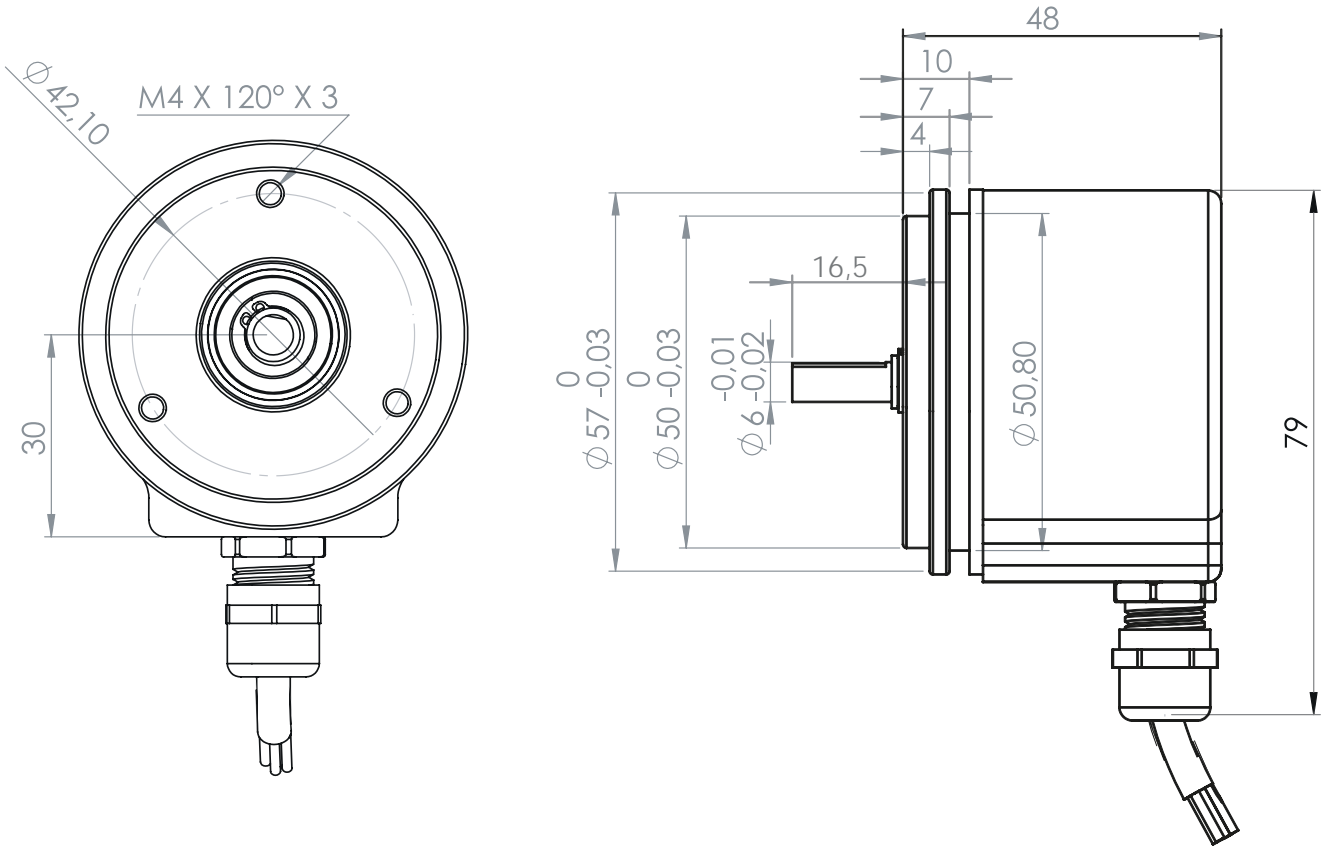

Mechanical Dimensions
Pulse Diagram, Cable / Connector Wiring

FNC Tacho 58S Series

Mechanical Dimensions



Cable Connection

Function	Color	Renk
+VB	 Brown	Kahve
GND	 White	Beyaz
V	 Green	Yeşil
A	 Red	Kırmızı
Shield	Black	Siyah

Pulse Diagram

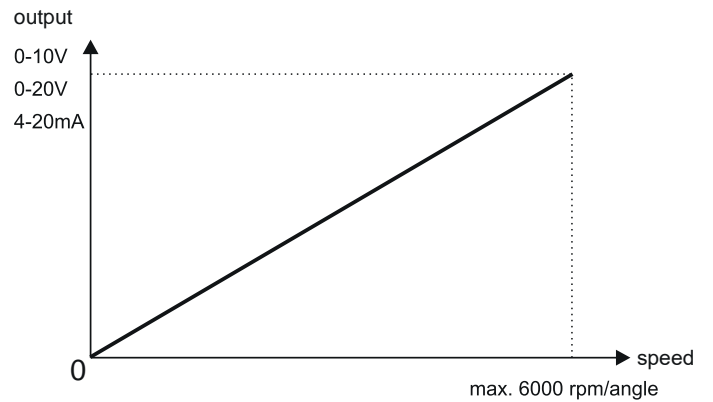

Tacho analog output versus speed

Part Number



FNC Tacho 58S Series

Encoder Part Number

